

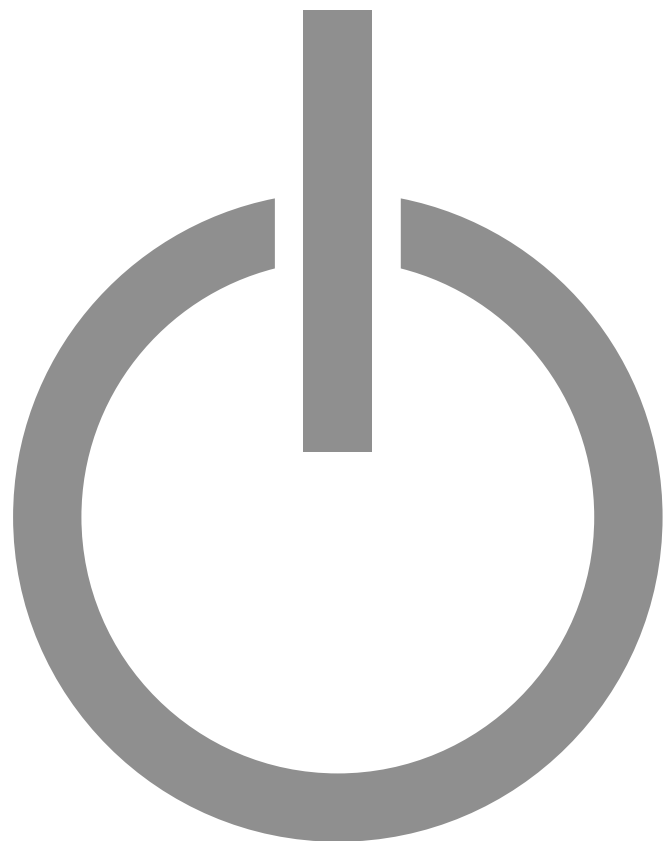

*Comfortable
heating. With wood!*

HDG Navora 20/25/30 with HDG Lambda Control 1





Content

1	Notes on this manual	5
1.1	Introduction	5
1.2	Structure of the operating manual.....	6
1.3	Glossary	7
2	Safety notes	8
2.1	Intended use	8
	Useful Organisations	9
	Basic principles for the construction of the system.....	9
	Proper and improper manner of operation	9
2.2	Residual risk.....	10
2.3	Warnings and safety symbols used	11
2.4	Duty to inform	13
3	Functional description.....	14
3.1	Sectional view	14
3.2	Mode of operation	17
	HDG Navora 20/25/30 with HDG Lambda Control 1 boiler	17
3.3	Technical data	19
3.4	Fuel quality requirements	20
	Residual moisture content	20
	Recommendation from HDG Bavaria GmbH	20
4	Using the HDG Navora Wood Boiler.....	21
4.1	Overview of the controls and display components.....	21
	Control panel HDG Lambda Control 1	21
4.2	Initialising the system	23
	Requirements	23
	Emergency heating switch	23
4.3	Structure of the menus	24
	“Heat production off” menu structure	24
	“Heat production on” menu structure.....	25
4.4	Displaying information	26
	Requirements	26
	How to display information	26
4.5	User changeable settings	29
	Requirements	29
	Setting the boiler temperature.....	29
4.6	Lighting and refuelling the HDG Navora	30
	How to proceed	30

5	Cleaning and maintaining the HDG Navora	39
5.1	Cleaning and maintenance plan	39
5.2	How to proceed	40
	Inspecting the heat exchanger cleaning system	41
	Removing ashes from the post-combustion chamber and ash compartment	43
	Inspecting the heat exchanger cleaning system	45
	Check the flue and clean if necessary	47
	Check the oxygen sensor and clean if necessary	48
	Inspecting and cleaning the flue gas sensor	49
	Inspecting and cleaning the flue fan	50
	Check the primary and secondary air actuators	52
	Inspecting the integrity of the door seals	53
	Clean the control panel	55
	Calibrate the oxygen sensor	55
	Clean the panels and the primary air inlets	56
6	Troubleshooting	60
6.1	How to proceed	60
6.2	Possible faults	61
	Faults which do not interrupt the production of heat	61
	Faults which interrupt the production of heat	62
7	Commissioning the HDG Navora	63
7.1	Conditions	63
7.2	Commissioning the HDG Navora	64
	Switching HDG Navora on	64
	Configuring the control	64
	Setting the target boiler temperature	67
	Customer data	68
	Memorandum for set values	68
	Testing system components	69
8	Notes on dismantling and disposal	72
8.1	Dismantling	72
8.2	Disposal	73
9	Warranty and extended warranty	74
9.1	Specification	74
9.2	Extended warranty conditions	74
9.3	Warranty exclusions	75
10	Declaration of conformity	76

1 Notes on this manual

1.1 Introduction

SAFE AND SIMPLE OPERATION

This Operation Manual contains important information for proper and safe operation of the HDG Navora 20/25/30 with HDG Lambda Control 1 boiler. Following these instructions means that danger can be avoided, repair costs and breakdowns can be prevented, reliability can be maintained and that the operational life of the heating system can be increased.

READING THE OPERATION MANUAL

This Operation Manual must be read and applied by everyone who operates or works on the HDG Navora 20/25/30 with HDG Lambda Control 1 boiler.

TECHNICAL CHANGES

We continuously develop and improve our boilers. The information in this version was correct at the time of going to press.

We reserve the right to make changes which may then deviate from the technical details and illustrations in this Operation Manual.

COPYRIGHT

Written agreement is required from HDG Bavaria GmbH for any reprints, storage in a data-processing system or transmission by electronic, mechanical, photographic or any other means, for copies or translations of this publication, in whole or in part.

SYMBOLS USED

In this Operation Manual the following presentation or symbols will be used for particularly important information:

1. Instructions to the operator
 2. Work through the steps in the sequence specified.
- ✓ The result of the action described
 - 📎 Cross reference for more explanation
 - List
 - List

1.2 Structure of the operating manual

The operating manual is structured as follows:

Chapter	Here you see, ...
1 Notes on this manual	... how to use this operating manual.
2 Safety notes	... everything on the subject of safety that you should consider when using the HDG Navora.
3 Functional description	... the structure and all of the features of the HDG Navora.
4 Using the HDG Navora	... how to properly operate the HDG Navora.
5 Cleaning and maintaining the HDG Navora	... how you can clean the HDG Navora and who is responsible for its maintenance.
6 Troubleshooting	... how you can remedy faults in the heating system.
7 Commissioning the HDG Navora	... how the HDG Navora is to be put into service.
8 Notes on dismantling and disposal	... what has to be considered when dismantling and disposing of the HDG Navora.
9 Warranty	... what the terms and conditions of the warranty are.
10 Appendix	... the EC Declaration of Conformity.

Table 1/1 - Structure of the operating manual

1.3 Glossary

Term	Explanation
Actuator	This is a component which carries out a certain function in the heating system.
Display	Display of the HDG Lambda Control unit.
Flue fan	Creates a negative pressure inside the boiler and supplies the boiler with air for combustion.
Flue gas by-pass flap	Facilitates the extraction of flue gas when the filling chute is opened and during refilling.
HDG Lambda Control	Microprocessor controller to regulate combustion and the heating of the accumulator.
HDG Navora 20/25/30 with HDG Lambda Control 1	Boiler for burning split logs.
Oxygen sensor	Electrical component which monitors residual oxygen levels in the flue gas.
Plug board	Pre-fabricated connection strip for connecting electrical components
Refill button	Button that must be pressed before the boiler is opened for refilling, or lighting a fire.
Refill signal	Electrical signal (in the form of an LED on the Lambda Control panel) which serves as a prompt to refill the fuelling chamber.
Sensor	Monitors certain parameters (e.g. temperature) and forwards them to the control system for analysis.
Thermal safety device	Safety device which allows cold water to flow through the safety heat exchanger if the boiler becomes too hot.

Table 1/2 - Glossary

2 Safety notes

2.1 Intended use

Please note that it is a legal requirement under England and Wales Building Regulations that the installation of the appliance is either carried out under Local Authority Building Control approval or is installed by a Competent Person registered with a Government approved Competent Persons Scheme. HETAS Ltd operate such a Scheme and a listing of their Registered Competent Persons can be found on their website at www.hetas.co.uk.

IMPORTANT

The installation of this appliance must comply with all local regulations, including those referring to national and European Standards before it can be operated.

This appliance is not suitable for a shared flue.

Improper adjustment, alteration, maintenance or the fitting of replacement parts not recommended by the manufacturer can cause injury or property damage. Do not operate the appliance with faulty seals or components.

Ensure all manuals are kept safely and are available for the user at all times.

Do not store or use petrol or other flammable vapours and liquids in the vicinity of this or any other heating appliance. Do not burn anything but natural wood.

Due to high operating temperatures of this appliance it should be located away from pedestrian traffic. Advise all persons as to the appliances high surface temperatures, including visitors. If it is possible for children or infirm adults to come into contact, fit a suitable guard. Never let children “help” with the appliance in any way, even when cold.

It is imperative that all air passageways into, out of, and within the appliance are kept clean. All permanent ventilation into the room provided must remain clear and unobstructed at all times. Consideration must be given to the need for extra ventilation if another heating source needing air is to be operated simultaneously. If an extraction fan is proposed to be fitted to a connecting area of the house, after the stove has been installed, professional advice should be sought from a qualified engineer.

If a flue blockage or adverse weather conditions cause the appliance to emit smoke, do not treat it as merely a nuisance, this smoke will indicate that carbon monoxide is being emitted into the room.

In the event of a chimney fire the appliance should be turned to its minimum setting and the fire brigade informed. Do not re-light until the complete installation has been inspected by a qualified engineer.

The appliance should be inspected regularly and the chimney cleaned at least annually. More frequent cleaning may be required and the advice of a qualified chimney sweep should be sought. Always check for any flue blockage before lighting the stove after a prolonged shut down.

This appliance has been carefully designed and constructed to give clean burning with optimum efficiency and safety, but as with all appliances these standards will not be achieved unless it is installed and maintained regularly by qualified engineers. It must also be operated strictly with the procedures given in this manual.

If you are unsure about anything concerning your appliance please seek professional advice.

USEFUL ORGANISATIONS

Name	Phone	Web
Solid Fuel Association	0845 601 4406	www.solidfuel.co.uk
The National Association of Chimney Sweeps	01785 811732	www.chimneyworks.co.uk
HETAS Ltd.	0845 634 5626	www.hetas.co.uk

Table 2/1 - Useful Organisations

BASIC PRINCIPLES FOR THE CONSTRUCTION OF THE SYSTEM

BASIC PRINCIPLES

The heating system was built using state of the art technology and conforms to recognised safety regulations. However, its use can result in the injury or death of the user or a third party or in impairments to the heating system itself or to other material goods. **Have your specialist heating company provide you with detailed instructions on the operation of the heating system.**

USING THE HEATING SYSTEM

Only use the heating system when it is in perfect condition. Use it properly, as intended, staying aware of safety and of the dangers involved, following the Operation Manual. Have any faults which could impair safety immediately fixed.

PROPER AND IMPROPER MANNER OF OPERATION

APPLICATION OF THE HEATING SYSTEM

The HDG Navora 20/25/30 with HDG Lambda Control 1 boiler is designed to burn untreated wood in the form of split logs up to 500 mm (19"), pressed briquettes and coarse wood chips, coarse grade, cross section of maximum 1000 mm² and not less than 600 mm²). Varnished, coated or impregnated wood should never be used for fuel.

Any other application is considered improper use. The manufacturer will accept no liability for any damage resulting from improper use. The operating company bears sole responsibility in such cases.

UK SMOKE CONTROL
AREAS

Proper use includes adherence to the installation, operation and maintenance requirements specified by the manufacturer.

Modification of the specified operating values will affect the heating system's control program and could lead to malfunctions. Only trained maintenance and operating personnel may undertake modifications to the operating values.

The use of materials with other technical burning characteristics requires comprehensive modification of the control parameters by qualified specialists.

The Navora 20, 25 and 30 models have been recommended for exemption under Section 21 of the Clean Air Act 1993 for use in smoke control areas when burning wood logs which are selected in accordance with the recommendations on fuel in this manual, see section “3.4 Fuel quality requirements” in chapter “3 Functional description”.

2.2 Residual risk

Despite all precautions, the following residual risks remain:



Caution!

Hot surface.

Contact with the hot surface of the boiler can lead to burns.

Wait until the boiler has cooled down before touching uninsulated components.



Warning!

Danger of asphyxiation due to carbon monoxide.

If the boiler is operating, carbon monoxide can be emitted through the open ash or fuel loading door.

Do not leave the ash or fuel loading door open any longer than necessary.



Caution!

Danger of fire

Working in areas marked with this symbol can lead to a fire.

Do not leave the combustion chamber and/or fuelling chamber door open any longer than necessary.

**Caution!**

Hand injuries

Working in areas marked with this symbol can lead to hand injuries.

**Danger!**

Danger from electrical current or voltage.

Work in areas marked with this symbol may only be done by a qualified electrician.

**Danger!**

Danger from explosion.

Work in areas marked with this symbol may only be performed exactly as specified by HDG Bavaria.

Improper operation can lead to explosions.

2.3 Warnings and safety symbols used

The following warnings and safety symbols are used in this Operation Manual:

**Danger!**

Danger from electrical current or voltage.

Work in areas marked with this symbol may only be done by a qualified electrician.

**Warning!**

Warning about a dangerous location.

Work on areas marked with this symbol can lead to serious injuries or to extensive material damage.

**Caution!**

Hand injuries

Working in areas marked with this symbol can lead to hand injuries.



Caution!

Hot surface

Work on locations marked with this symbol can lead to burns.



Caution!

Danger of fire

Working in areas marked with this symbol can lead to a fire.



Caution!

Frost danger

Working in areas marked with this symbol can lead to frost damage.



Danger!

Danger from explosion.

Work in areas marked with this symbol may only be performed exactly as specified by HDG Bavaria.

Improper operation can lead to explosions.



Caution!

Danger from suspended loads.

Working in areas with this symbol may involve danger from falling objects.



Notes on disposal.



Additional information for the operator.



2.4 Duty to inform

READING THE OPERATION MANUAL

Everyone who works on the system must have read the Operation Manual before starting work and, in particular, have read the chapter “2 Safety notes”.

This holds especially true for persons who only occasionally work on the system, e.g. when cleaning or maintaining the heating system.

The Operation Manual must be kept easily accessible at the heating system's installation location.

3 Functional description

3.1 Sectional view

The boiler contains the following components:

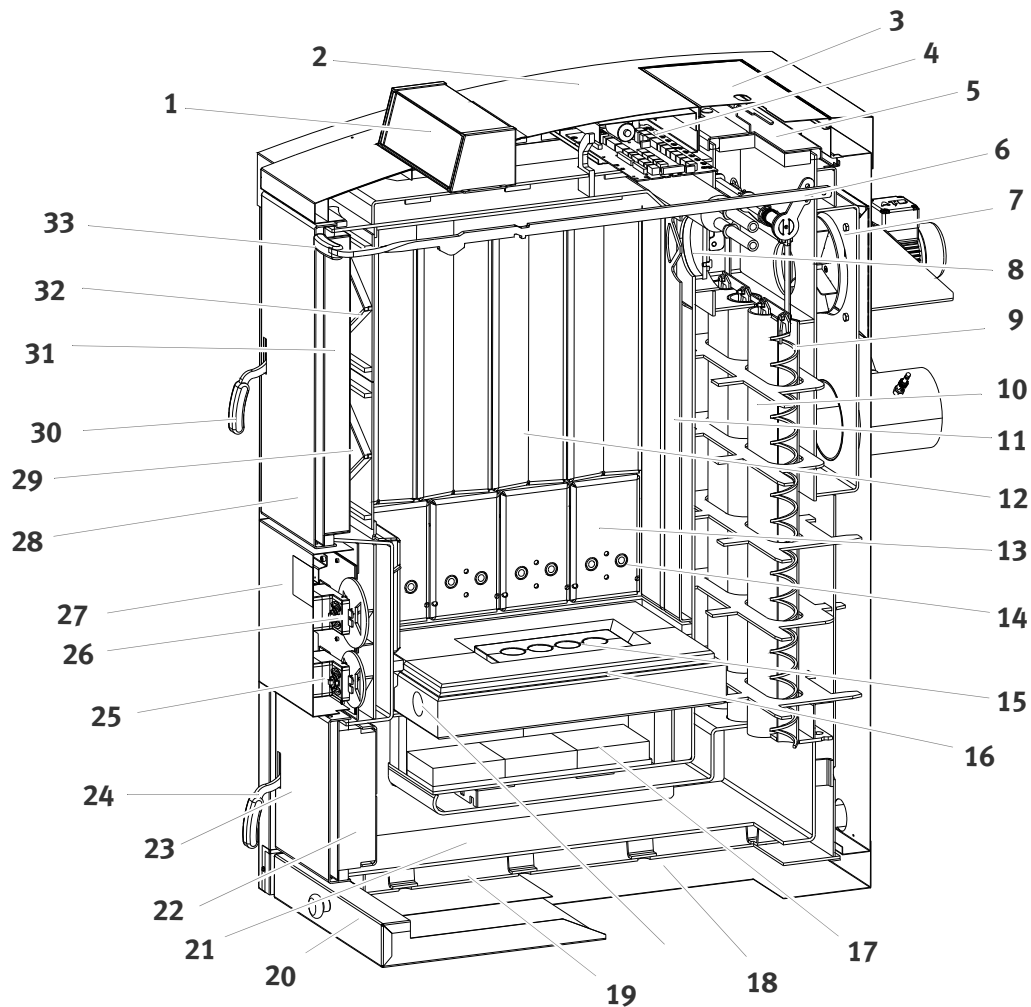

Figure 3/1 - Overview

- 1 HDG Lambda Control 1 control unit
- 2 Top cover
- 3 Cleaning lid cover
- 4 Plug board
- 5 Cleaning lid with heat shield
- 6 Latching mechanism for cleaning/flue gas by-pass flap
- 7 Flue gas collection box
- 8 Flue gas by-pass flap
- 9 Turbulator



- 10 Flue gas heat exchanger (top heating surfaces)
- 11 Combustion chamber panel, rear
- 12 Combustion chamber panel, top
- 13 Combustion chamber panel, bottom
- 14 Primary air inlet
- 15 Burner nozzle
- 16 Nozzle bed
- 17 Secondary combustion chamber with refractory lining
- 18 Base insulation cassette
- 19 Water jacket, bottom
- 20 Ash drawer
- 21 Ash compartment
- 22 Heat shield for combustion chamber door
- 23 Combustion chamber door
- 24 Combustion chamber door handle
- 25 Air adjustment flap for secondary air with servo motor
- 26 Air adjustment flap for primary air with servo motor
- 27 Front cover
- 28 Fuelling chamber door
- 29 Lower inside door
- 30 Fuelling chamber door handle
- 31 Heat shield for Fuelling chamber door
- 32 Upper inner fuelling door
- 33 Actuating handle for flue gas by-pass flap/cleaning system

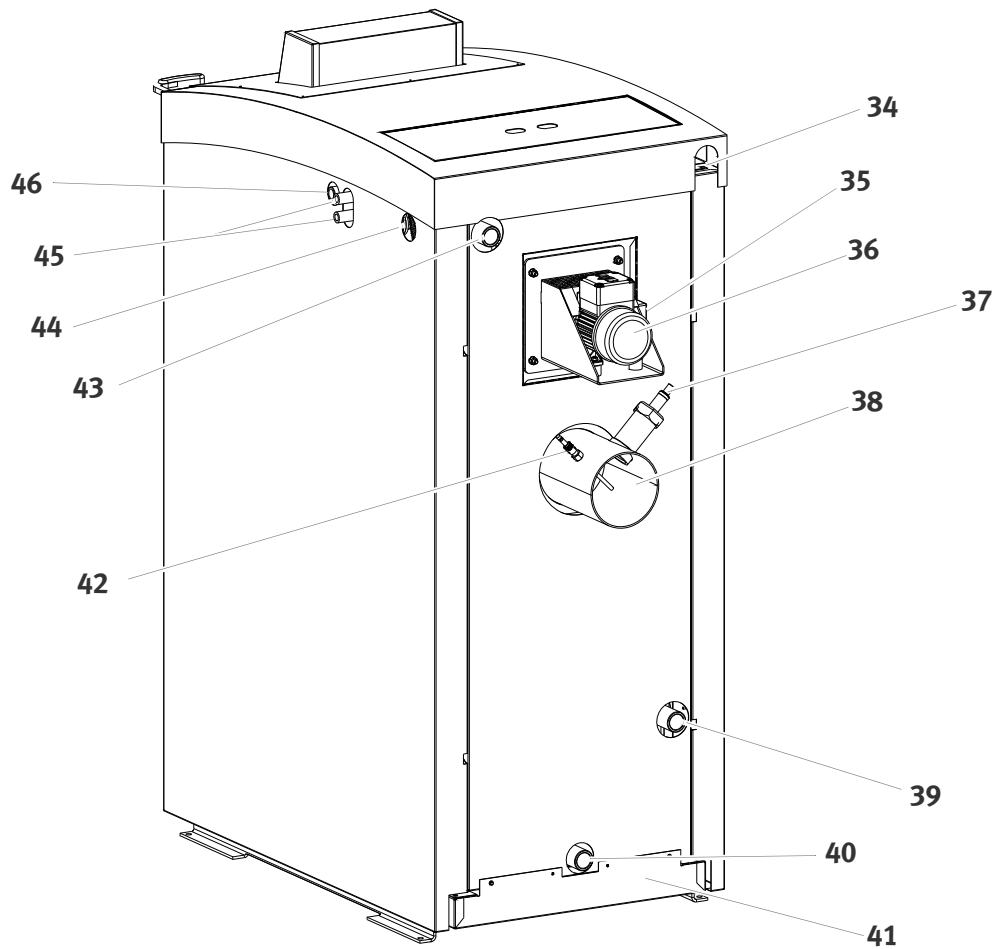

Figure 3/2 - Overview

- 34 Electrical cable inlet
- 35 Flue electrical connection
- 36 Flue fan
- 37 Oxygen sensor
- 38 Flue connection
- 39 Return connection 1 1/4" BSP (DN 32 IG)
- 40 Filling/draining 1" BSP (DN 25 IG)
- 41 Insulation cassette
- 42 Flue gas temperature sensor
- 43 Flow connection 1 1/4" BSP (DN 32 IG)
- 44 Inspection opening for boiler temperature sensor
- 45 Safety heat exchanger connections 1/2" BSP (DN 15 AG)
- 46 Connection for immersion pocket on thermal safety device 1/2" BSP (DN 15 AG)

3.2 Mode of operation

HDG NAVORA 20/25/30 WITH HDG LAMBDA CONTROL 1 BOILER

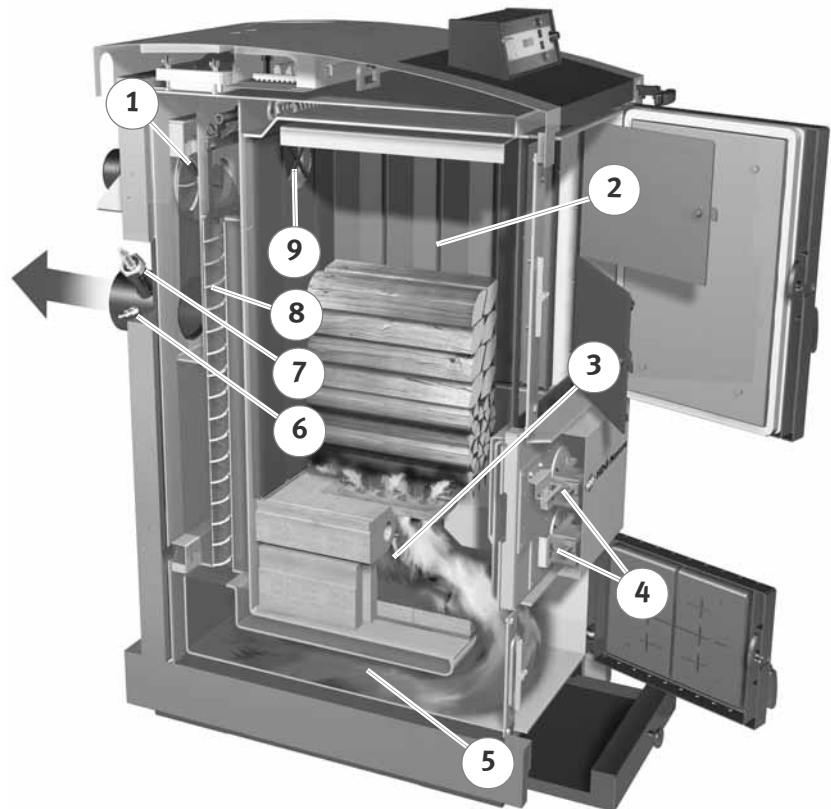

Figure 3/3 - Boiler HDG Navora 20/25/30 with HDG Lambda Control 1

Inside the HDG Navora 20/25/30 with HDG Lambda Control 1 boiler, fuel which has been manually placed in the fuelling chamber (2) and ignited is degassed through the addition of primary air.

The resulting wood gas is mixed with secondary air in the combustion chamber (3) where it is burnt.

Ashes are collected in the large ash compartments (5) for combustion ash and fly ash.

The air necessary for combustion is supplied as required via the suction fan (1) and two servo drives with metering mechanisms (4).

Via the oxygen sensor (7), the boiler temperature sensor (not visible in Figure 3/3 - Boiler HDG Navora 20/25/30 with HDG Lambda Control 1) and the flue gas temperature sensor (6):

- the firing is permanently monitored,
- the boiler output is adjusted,
- emissions are minimised and
- boiler efficiency is optimised.

CLEANING SYSTEM

The top heating surfaces are cleaned by activating the flue gas bypass flap (9), which is coupled with the turbulators (8) located in the top heating surfaces.

The HDG Navora 20/25/30 with HDG Lambda Control 1 is a specifically designed boiler for the firing of wood up to 500 mm in length. The HDG Lambda Control 1 control system regulates combustion, boiler output and the charging of the accumulator. The HDG Navora 20/25/30 with HDG Lambda Control 1 system are harmonised with one another and form a functional unit. This enables wood to be converted into heat energy in an environmentally sound and convenient manner.

HDG LAMBDA CONTROL 1

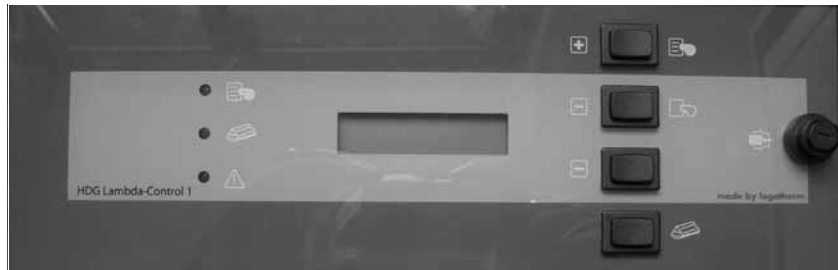



Figure 3/4 - HDG Lambda Control 1 control panel

The HDG Lambda Control 1 boiler control unit is the electronic hub. Via the control unit, you can manage the HDG Lambda Control 1 control system and call up information about the current operating status.

 See the section “4.3 Structure of the menus” in chapter “4 Using the HDG Navora Wood Boiler”.

3.3 Technical data

Type of boiler	HDG Navora 20	HDG Navora 25	HDG Navora 30
Minimum output	18 kW	18 kW	18 kW
Nominal output for wood	20 kW	25 kW	30 kW
Boiler class	3	3	3
Weight	680 kg	680 kg	680 kg
Max. operational pressure	3 bar	3 bar	3 bar
Max. supply temperature	95 °C	95 °C	95 °C
Water capacity	168 l	168 l	168 l
Necessary working pressure	15 Pa (0.06 "wg)	15 Pa (0.06 "wg)	15 Pa (0.06 "wg)
Exhaust mass flow <ul style="list-style-type: none"> Nominal load Partial load 	0.014 kg/s 0.012 kg/s	0.016 kg/s 0.012 kg/s	0.019 kg/s 0.012 kg/s
Exhaust temperature (approx.) <ul style="list-style-type: none"> Nominal output Minimum output 	140 °C 120 °C	150 °C 120 °C	160 °C 120 °C
Fuelling chamber capacity	150 l	150 l	150 l
Burning duration per filling, in accordance with fuel recommendations	Up to 6 h with beech, up to 4 h with spruce	Up to 6 h with beech, up to 4 h with spruce	Up to 6 h with beech, up to 4 h with spruce
Boiler efficiency	91 %	91 %	91 %
Electrical connection <ul style="list-style-type: none"> Voltage Current consumption for continuous operation 	230 V 0.76 A	230 V 0.76 A	230 V 0.76 A
Necessary auxiliary energy <ul style="list-style-type: none"> Constant operation at nominal power 	111 W	111 W	111 W
Diameter of flue supports	150 mm	150 mm	150 mm
Height of flue connection	900 mm	900 mm	900 mm
Safety heat exchanger connections (bushing)	2 x 1/2" BSP (DN 15)	2 x 1/2" BSP (DN 15)	2 x 1/2" BSP (DN 15)

Table 3/1 - Technical data HDG Navora 20/25/30 with HDG Lambda Control 1

Type of boiler	HDG Navora 20	HDG Navora 25	HDG Navora 30
Flow and return connections (bushing)	1 1/4" BSP (DN 32)	1 1/4" BSP (DN 32)	1 1/4" BSP (DN 32)
Drain (bushing)	1" BSP (DN 25)	1" BSP (DN 25)	1" BSP (DN 25)
Water-side resistance at $\Delta\theta$ 10 K	13 hPa	13 hPa	13 hPa
Water-side resistance at $\Delta\theta$ 20 K	1.5 hPa	1.5 hPa	1.5 hPa
Air inlet cross section	15.000 mm ²	15.000 mm ²	15.000 mm ²

Table 3/1 - Technical data HDG Navora 20/25/30 with HDG Lambda Control 1

3.4 Fuel quality requirements

RESIDUAL MOISTURE CONTENT

When selecting fuel, it is important to understand that the thermal value of the wood is primarily dependent upon the moisture content. For the purpose of simplifying cost calculations, you can assume that 1 kg of wood (all types) with a moisture content of 20 % has a thermal value of approx. 4 kWh. Firewood must be split and its size must be adapted accordingly to fit in the fuelling chamber.

Unsplit logs and square boards are not suitable for burning.

Moreover, logs should be split before they are prepared for drying. This is done in order to achieve a moisture content which is suitable for burning within a reasonable amount of time (approx. two years).

Moist, unsplit wood has a negative impact on the combustion efficiency of the boiler and results in higher fuel consumption.

RECOMMENDATION FROM HDG BAVARIA GMBH

HDG Bavaria recommends split logs in lengths of 500 mm (19"), with a max. edge length of 120 mm (4 3/4") and a moisture content of 20 %.

4 Using the HDG Navora Wood Boiler

4.1 Overview of the controls and display components

CONTROL PANEL HDG LAMBDA CONTROL 1

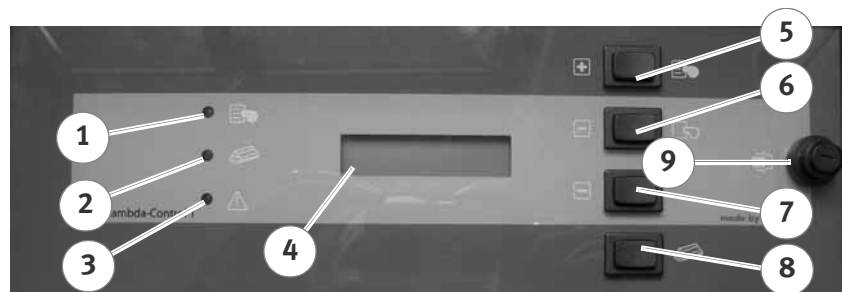



Figure 4/1 - HDG Lambda Control 1 control panel

- 1 “Heat production on” indicator
- 2 “Refill” indicator
- 3 “Fault” indicator
- 4 Text display
- 5 “Heat production on/plus” button
- 6 “Heat production off/minus” button
- 7 “Arrow” button
- 8 “Refill” button
- 9 Unlocking knob for the safety temperature limiter (STB)

The HDG Lambda Control 1 control panel is located on the top of the HDG Navora 20/25/30 with HDG Lambda Control 1 boiler.

Via the control unit, you can manage the HDG Lambda Control 1 control system and call up information about the current operating status.

The display shows the selected information and settings. In the operating mode “Heat production on”, the display is switched on and active. In the operating mode “Heat production off/minus”, the display switches off after 15 minutes. It can be switched on again by pressing any button.

 In section “4.3 Structure of the menus” in this chapter, all selectable information and parameters are listed.

DISPLAY

“HEAT PRODUCTION ON”
INDICATOR



The **“Heat production on”** indicator (1) lights up when the combustion process is initiated by pressing the *“Heat production on”* button (5), or when the process starts automatically (if the exhaust flue temperature is sufficient). The indicator goes out when the combustion process is stopped via the *“Heat production off”* button, or when the process is automatically stopped due to lack of fuel.

“REFILL” INDICATOR



The **“Refill”** indicator (2) lights up when heat production has been switched off or when system heating requirements necessitate a refill. The indicator will blink while the system is waiting to be refilled and it will go out when heat production is switched on.

See the section “4.6 Lighting and refuelling the HDG Navora” in this chapter.

“FAULT” INDICATOR



The **“Fault”** indicator (3) lights up when faults occur which: prevent the further production of heat, or prevent heat production from being switched on. It will blink when faults occur which: allow for heat production to continue, or still allow heat production to be switched on (e.g. control set to an alternative programme until the fault is resolved). It will go out when faults have been acknowledged and remedied.

KEYPAD

The HDG Navora can be operated via the keypad. The various buttons have the following functions:



“Heat production on/plus” button

- In menu level 1, the system is switched into “Heat production on” operating mode
- In the submenu, parameters can be selected and their respective settings can be changed.



“Heat production off/minus” button

- In menu level 1, the system is switched into “Heat production off” operating mode, or the refill function is prematurely stopped.
- In menu level 2, parameters can be selected and their respective settings can be changed.



“Arrow” button

- Accesses the selection menu.
- Confirms the function selected with the “Plus” or “Minus” buttons.

Confirms changes to settings.



“Refill” button

- The flue fan is activated when the button is pressed. Instructions on how to proceed with opening the filling hatch will appear in the display of the HDG Lambda Control 1.
- 🔧 See section “4.6 Lighting and refuelling the HDG Navora” in this chapter.
- Unlocking knob for the safety temperature limiter (*STB*). If the *STB* is triggered as a result of the boiler temperature being too high, the *STB* has to be reset by pressing the reset knob after the boiler temperature has dropped to approx. 80 ° C. The fault is automatically reset.



4.2 Initialising the system

REQUIREMENTS



In order for the HDG Navora to be switched on, it must have been put into service by an authorised specialist.

🔧 See chapter “7 Commissioning the HDG Navora”.

EMERGENCY HEATING SWITCH

The HDG Navora is connected to the mains supply through a fused spur isolation switch which would have been installed by the installer.



Danger!

Danger from electrical current or voltage.

The HDG Navora and connected controls can only be completely de-energised by switching off the fused spur.

1. Switch on the HDG Navora at the corresponding fused spur.
- ✓ The HDG navora ready for operation.

4.3 Structure of the menus

“HEAT PRODUCTION OFF” MENU STRUCTURE

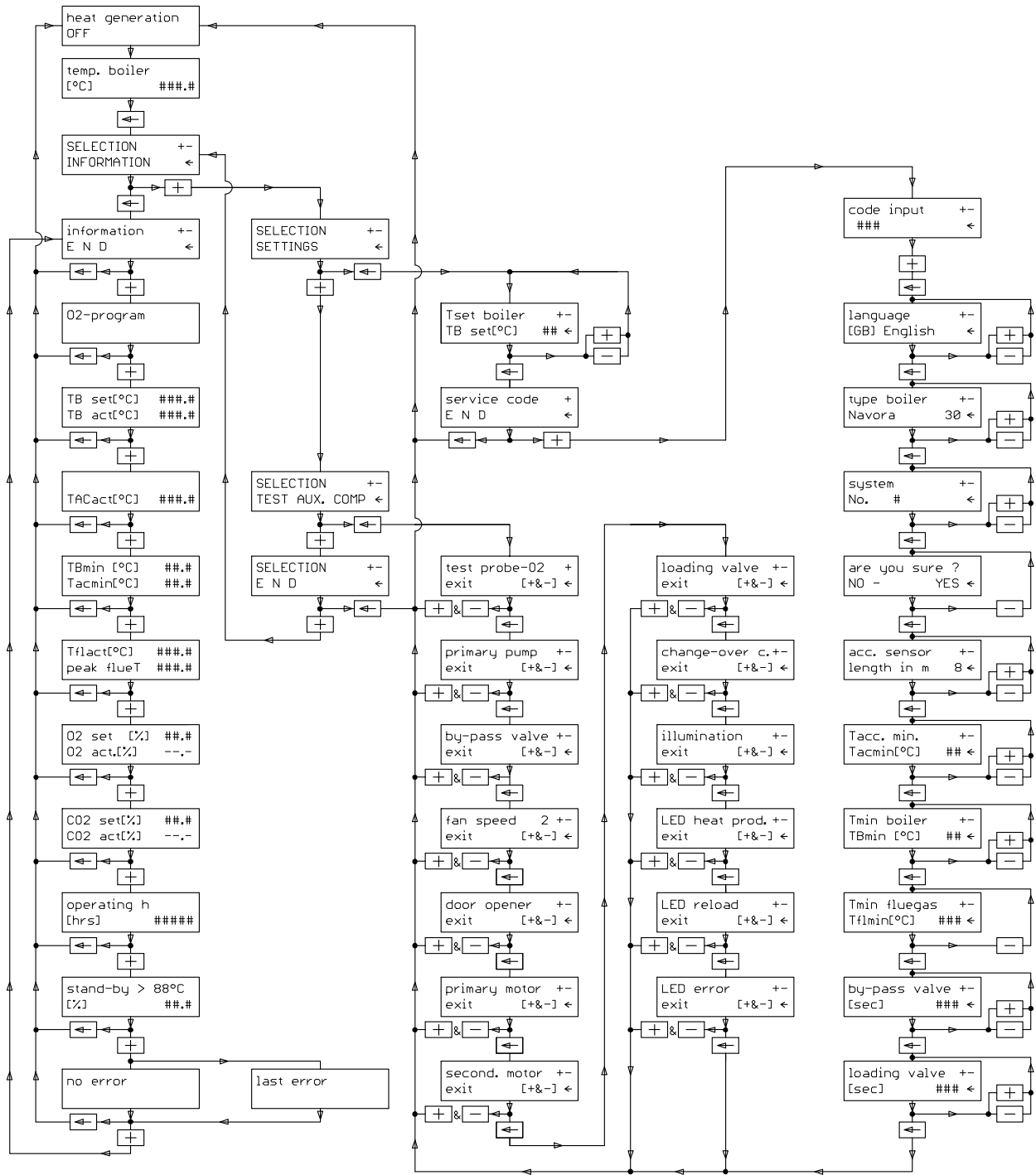

Figure 4/2 - “Heat production off” menu structure

“HEAT PRODUCTION ON” MENU STRUCTURE

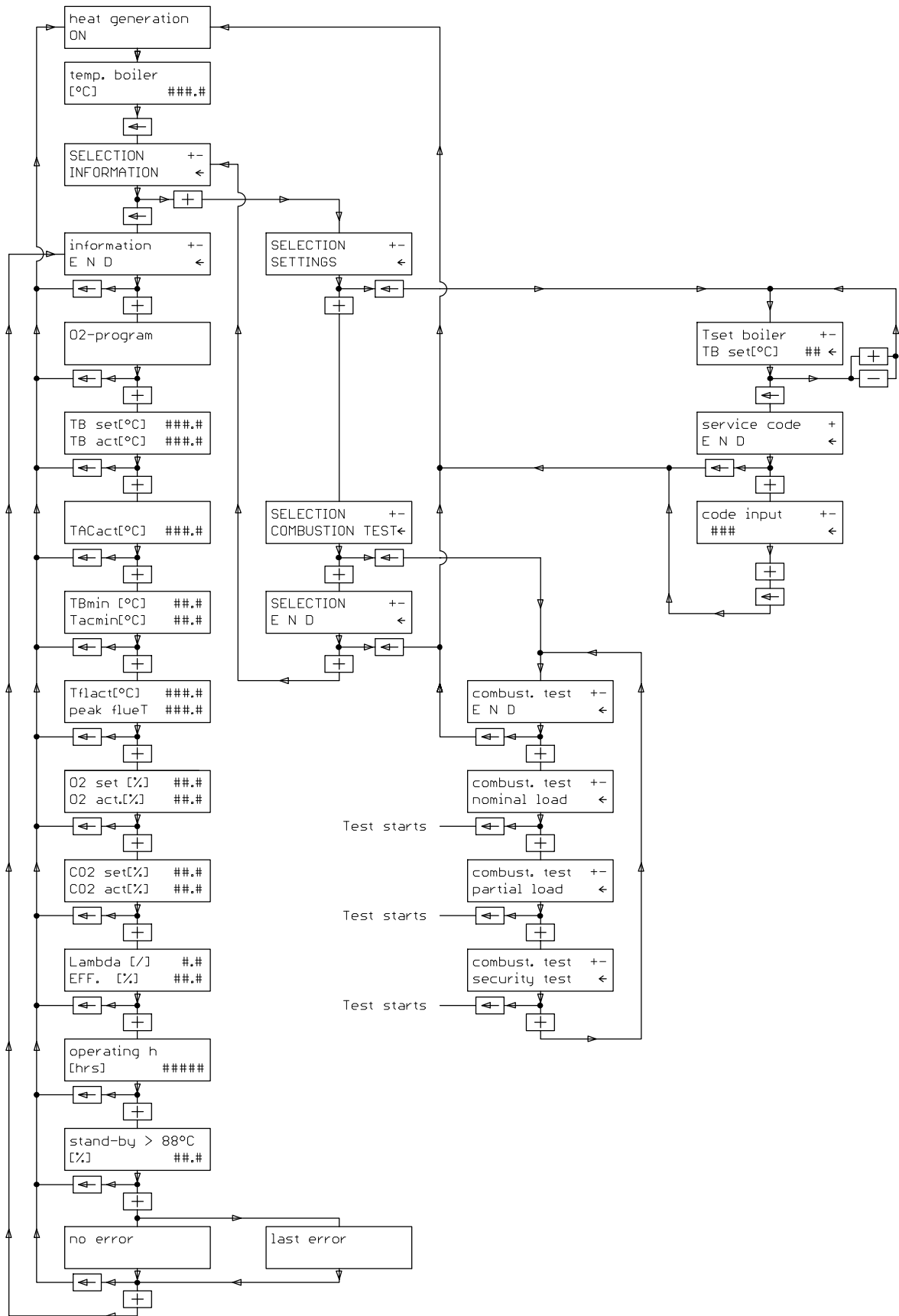



Figure 4/3 - “Heat production on” menu structure

4.4 Displaying information

You can call up a variety of information on the display of the HDG Lambda Control 1.



Certain information and settings can only be accessed and changed in “Heat production on” or “Heat production off”.

 See section “4 Using the HDG Navora Wood Boiler” in chapter “4.3 Structure of the menus”.

REQUIREMENTS

Before the HDG Navora can be switched on and information and settings can be accessed and changed, the following requirements must be met.

- The HDG Navora has been commissioned by authorised specialists.
- The switch on the power supply is switched on.

HOW TO DISPLAY INFORMATION



The buttons on the control panel of the HDG Lambda Control must be pressed and held for approx. two seconds in order to jump to another menu item.

If a button is not pressed after 30 seconds, the selection menu will be abandoned automatically.

 See chapter “4 Using the HDG Navora Wood Boiler”, section “4.1 Overview of the controls and display components”.

SELECTION MENU IN “HEAT PRODUCTION OFF” MODE

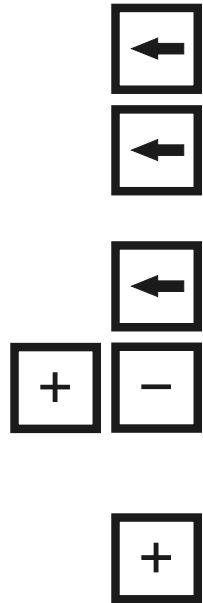
- 
1. Press the *Arrow* button.
✓ The display is activated.
 2. Press the *Arrow* button.
✓ The selection menu **Selection** submenu **Information** will appear in the display.
 3. Press the *Arrow* button.
✓ **Information** and **End** will appear in the display.
 4. Press the *Plus* button to scroll forward through the information or *Minus* to scroll backwards through the information.
✓ The **O2 Control program** information is displayed by pressing the Plus button.
 5. Continue pressing the *Plus* button until you have obtained all of the desired information.

ACCESSIBLE INFORMATION

Preset target values, current actual values and analyses:

Display			Description	Authorised
TK S	[°C]	82.0	<ul style="list-style-type: none"> Maximum required boiler water temperature. 	Operator
TK I	[°C]	73.4	<ul style="list-style-type: none"> Current actual value. 	
TS I	[°C]	23.8	<ul style="list-style-type: none"> Current accumulator temperature. 	No access
TK min	[°C]	60.0	<ul style="list-style-type: none"> Required minimum boiler temperature. Required minimum accumulator temperature. 	Operator
TS min	[°C]	45.0		Operator
TA I	[°C]	23.0	<ul style="list-style-type: none"> Current flue gas temperature. Highest flue gas temperature reached since the last enquiry. 	No access
Peak value		226.0		
O2 S	[%]	6.0	<ul style="list-style-type: none"> Preset target value for residual oxygen Current actual value for residual oxygen 	Manufacturer
O2 I	[%]	5.6		
CO2 S	[%]	15.4	<ul style="list-style-type: none"> Target value for carbon dioxide Calculated actual value for carbon dioxide. 	No access
CO2 I	[%]	15.8		
Lambda	[/]	1.9	<ul style="list-style-type: none"> Current excess air coefficient Current degree of combustion efficiency 	No access
ETA-F	[%]	100.0		
Operating hours			<ul style="list-style-type: none"> Cumulative operating hours in “Heat production on” mode. 	No access
	[h]			

Table 4/1 - Target value information

Display	Description	Authorised
stand-by > 88°C [%]	<ul style="list-style-type: none"> • Display of the percentage of operating hours during which the boiler temperature was above 88 °C (*). 	No access
Last fault	<ul style="list-style-type: none"> • Most recent fault since the last enquiry. 	Operator

Table 4/1 - Target value information



(*). If this value is too high, there is a danger of excessive contamination of the boiler and the chimney!

Danger of fire in the chimney and flue!

See the following example calculation.

EXAMPLE CALCULATION FOR OPERATIONAL READINESS

1000 operating hours at 20 % readiness equates to 200 hours with the boiler temperature above 88°C.

Consequence: The boiler would thus have been **overheated** for 200 hours.

Control programmes:

Control programme	Indication in display	Description
Standard control programme	O ₂ control programme	<ul style="list-style-type: none"> • Combustion is regulated according to the residual oxygen content as measured by the O₂ sensor
Alternative control programme	TA control programme	<ul style="list-style-type: none"> • If the O₂ sensor malfunctions or is defective, the HDG Lambda Control microprocessor controller switches from the standard control programme to the alternative control programme and uses the exhaust temperature to regulate combustion, thus ensuring temporary emergency operation

Table 4/2 - Control programme information



Indication in display when the “**TA control programme**” alternative control programme is automatically initiated.

4.5 User changeable settings

REQUIREMENTS

In order to be able to proceed with making changes and corrections to the settings, the following requirements must be met.

- The HDG Navora has been commissioned by authorised specialists.
- The switch on the power supply is switched on.

SETTING THE BOILER TEMPERATURE.

SELECTION MENU IN “HEAT PRODUCTION OFF” MODE

The display reads **Heat production off.**

1. Press the *Arrow* button.
 - ✓ The selection menu **Selection** submenu **Information** will appear in the display.
2. Press the *Plus* button.
 - ✓ The display changes to the **Settings** submenu.
3. Press the *Arrow* button.
 - ✓ The menu item is confirmed; **Boiler target value TK S [°C]** appears in the display.
4. Use the *Plus* button to increase the value, or the *Minus* button to reduce the value.

The available setting range is between 78 and 85 °C, the standard setting is 80 °C.

 - ✓ The desired value is set.
5. Press the *Arrow* button.
 - ✓ The target boiler temperature is assumed.
6. Press the *Arrow* button.
 - ✓ The submenu is exited and **Heat production off** appears in the display again.
 - ✓ The boiler target temperature is set.
 - 🔗 See section “4.3 Structure of the menus” in this chapter for more information.

4.6 Lighting and refuelling the HDG Navora

HEATING UP WHEN THE SYSTEM IS COLD

HOW TO PROCEED

Despite all precautions, the following residual risks remain:



Caution!

Hot surface.

Contact with the hot surfaces of the boiler can lead to burns.

Wait until the boiler has cooled down before touching uninsulated components.



Warning!

Danger of asphyxiation due to carbon monoxide.

If the boiler is operating, carbon monoxide can be emitted through the open filling hatch.

Do not leave the combustion chamber and/or filling hatch open any longer than necessary.



Caution!

Danger of fire

Working in areas marked with this symbol can lead to a fire.

Do not leave the filling hatch open any longer than necessary.



Danger!

Danger of explosion.

Work in areas marked with this symbol may only be performed exactly as specified by HDG Bavaria.

Improper operation can lead to explosions.

When the “Refill” indicator lights up, there are no more embers in the filling chamber.

 See section “4.1 Overview of the controls and display components” Paragraph “Control panel HDG Lambda Control 1” in this chapter for more information.



1. Press the *Refill* button.

✓ The “**Do not open, please wait**” message will appear in the display of the HDG Lambda Control control unit.

✓ The flue fan starts to run.

2. Lift up the door handle (2) and open the outer filling hatch (1).

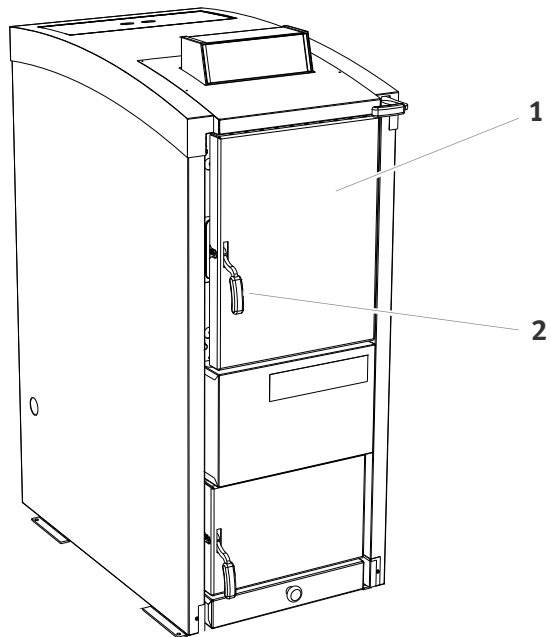

Figure 4/4 - Heating up/refilling

3. Pull out the handle (1) for the flue gas by-pass flap until it stops, then lower it down.

✓ The flue gas by-pass flap is now locked.

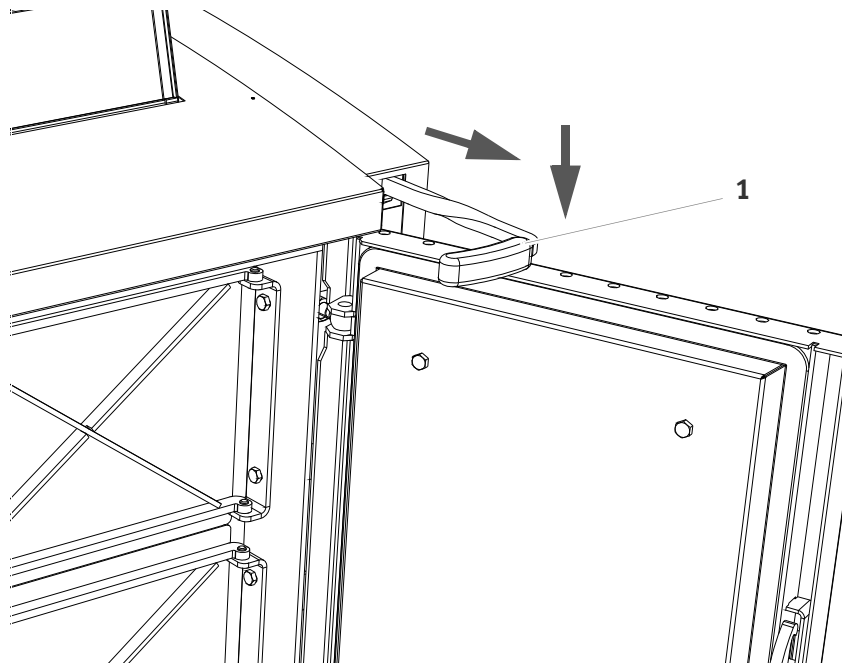

Figure 4/5 - Lighting and refuelling

4. Wait for approx. 15 seconds until the "Careful, open slowly" message appears.

- ✓ The “Careful, open slowly” message appears.
- 5. Open the top inside door (3) first.
- 6. Insert the door opening tool (2) into the hole in the door handle on the top inside door, then open the door slowly.

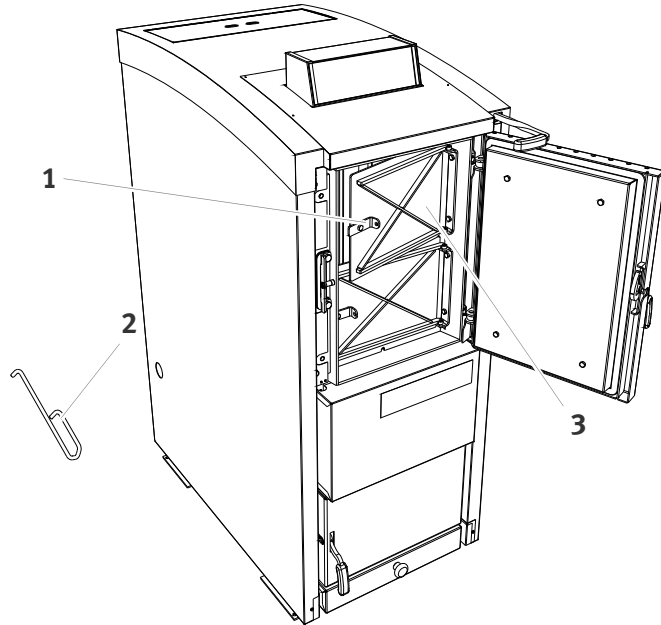

Figure 4/6 - Lighting and refuelling

- 7. Repeat the procedure in step 6 and open the lower inside door (3).

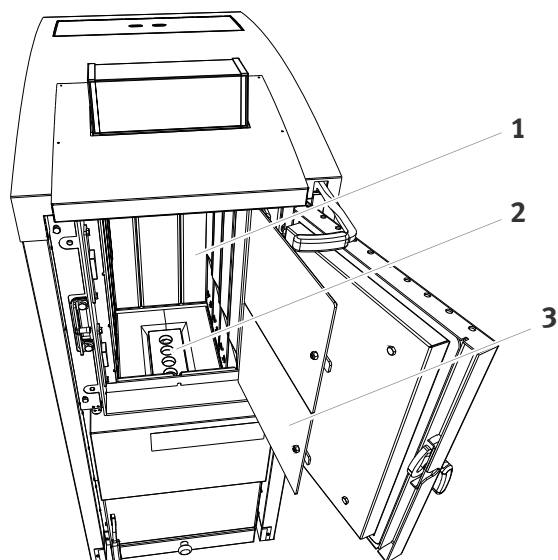

Figure 4/7 - Lighting and refuelling

- 8. Leave any remaining unburnt pieces of wood and charcoal in the fuelling chamber (1).

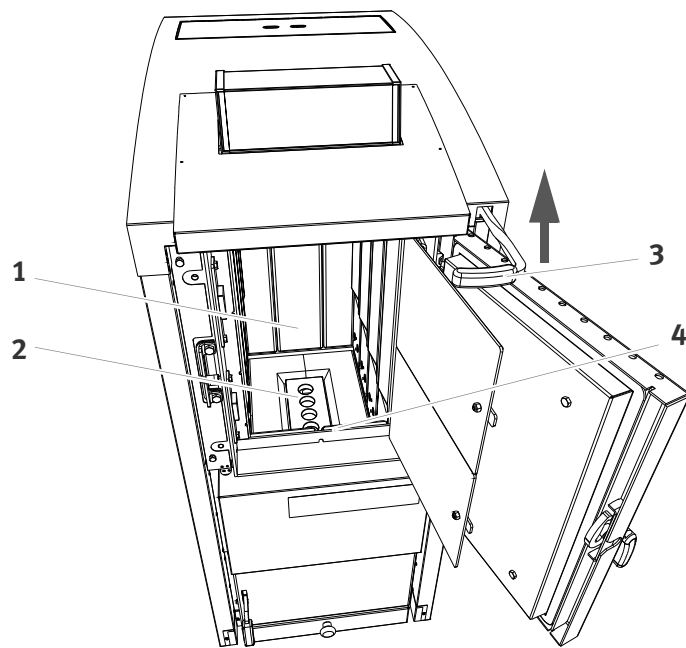



Figure 4/8 - Lighting and refuelling

9. Place highly flammable material (small pieces of dry wood kindling) onto the burner nozzle (1). Fill to a depth of approx. 100 mm (4") so that the burner nozzle (2) is covered.
10. Lay some small pieces of cardboard on top of the wood inside the fuelling chamber (1).
11. Place 3 or 4 sheets of crumpled up newspaper in the fuelling chamber in such a way that it can be reached from the edge (4) of the fuelling chamber.
12. Fill the fuelling chamber with a quantity of wood that corresponds to the heat required by the accumulator.



Only fill with as much wood as the HDG Navora and accumulator can absorb as energy.

 See section “3.4 Fuel quality requirements” in chapter “3 Functional description”.

13. Close the flue gas by-pass flap by pushing the handle (3) upwards.
14. Ignite the cardboard or paper in the fuelling chamber.
15. Allow the fuel to generate a good fire.

16. Close the top inside door (1).

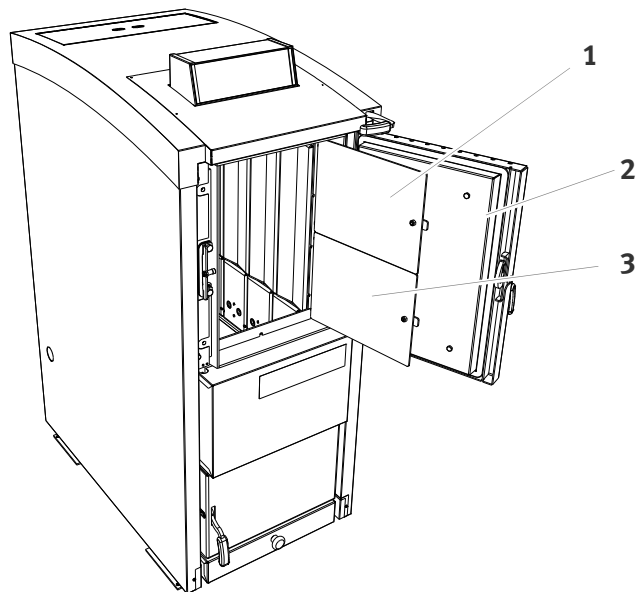

Figure 4/9 - Lighting and refuelling

17. Leave the lower inside door (3) ajar (100 to 150 mm) until the "Heat production on" message appears in the display and the "Heat production on" indicator lamp lights up.

✓ The "Heat production on" message in the display and the "Heat production on" indicator lamp appear when the required exhaust temperature is reached.

18. Close the lower inside door (3).

19. Close the filling hatch (2).

✓ The log wood boiler is now operating and automatically controlling its combustion and heat output.

REFUELLING

Despite all precautions, the following residual risks remain:

**Caution!**

Hot surface.

Contact with the hot surfaces of the boiler can lead to burns.

Wait until the boiler has cooled down before touching uninsulated components.

**Warning!**

Danger of asphyxiation due to carbon monoxide.

If the boiler is operating, carbon monoxide can be emitted through the open filling hatch.

Do not leave the combustion chamber and/or filling hatch open any longer than necessary.

**Caution!**

Danger of fire

Working in areas marked with this symbol can lead to a fire.

Do not leave the filling hatch open any longer than necessary.



Always check the integrity of the filling hatch seal before heating up the system.

**Danger!**

Danger of explosion.

Work in areas marked with this symbol may only be performed exactly as specified by HDG Bavaria.

Improper operation can lead to explosions.

When the “Refill” indicator lights up, there are no more embers in the filling chamber.

🔧 See section “4.1 Overview of the controls and display components” Paragraph “Control panel HDG Lambda Control 1” in this chapter for more information.



1. Press the *Refill* button.

✓ The “**Do not open, please wait**” message will appear in the display of the HDG Lambda Control control unit.

✓ The flue fan starts to run.

2. Lift up the door handle (2) and open the outer filling hatch (1).

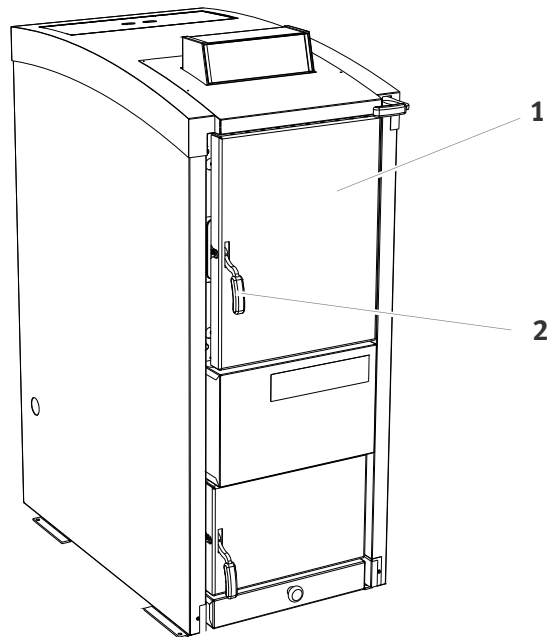

Figure 4/10 - Lighting and refuelling

3. Pull out the handle (1) for flue gas by-pass flap until it stops, then lower it down.

✓ The flue gas by-pass flap is now open.

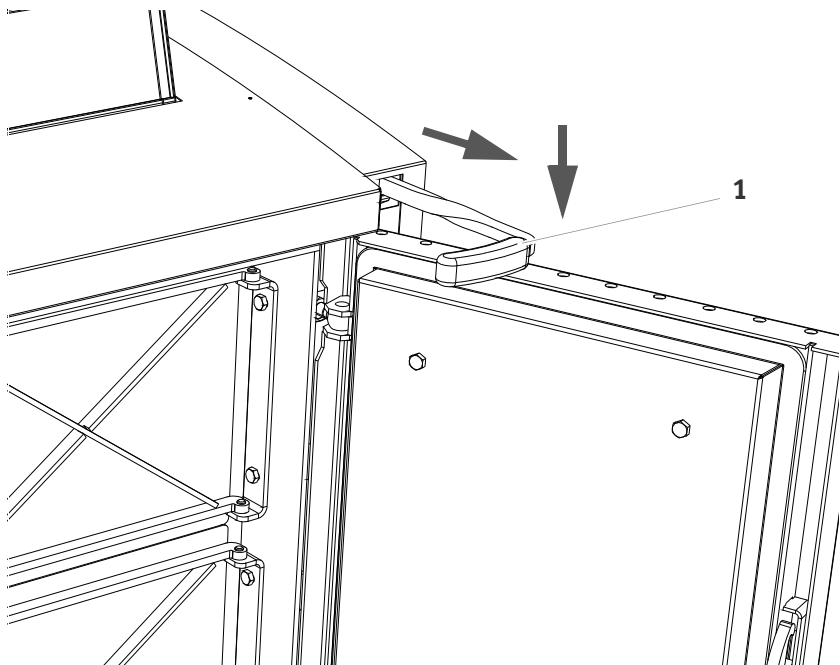

Figure 4/11 - Lighting and refuelling

4. Wait for approx. 15 seconds until the **“Careful, open slowly”** message appears on the display.

- ✓ The **“Careful, open slowly”** message appears.
- 5. Open the top inside door (3) first.
- 6. Insert the door operating tool (2) into the hole in the door handle (1) on the top inside door (3), then open the door slowly.

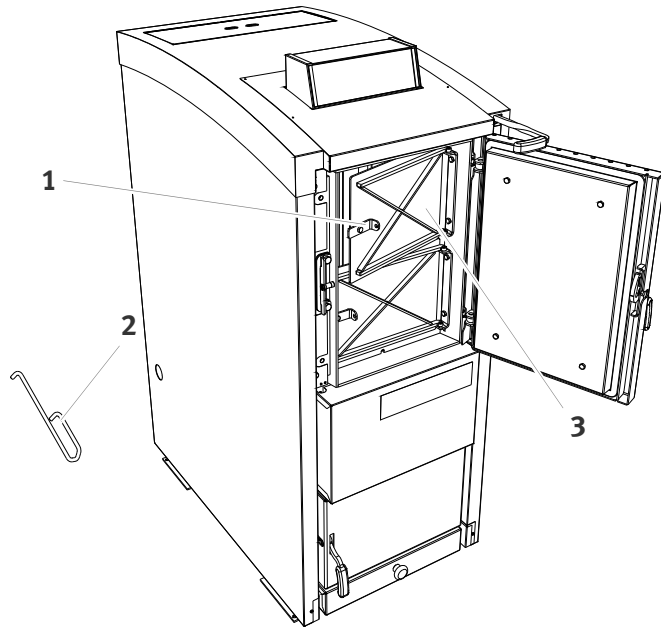

Figure 4/12 - Lighting and refuelling

- 7. If there are only a few residual embers, place small pieces of combustible material (kindling) on the embers in the fuelling chamber (1).

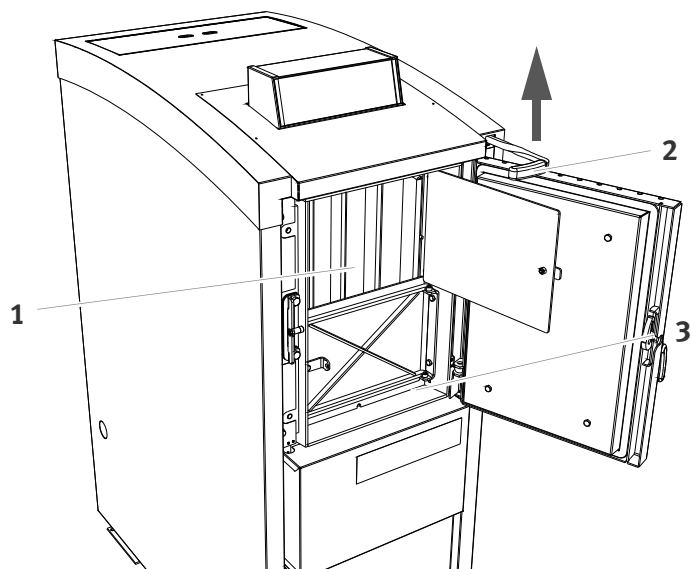

Figure 4/13 - Lighting and refuelling

- ✓ The pieces of combustible material will ignite.
- 8. Fill the fuelling chamber (1) with an amount of seasoned dry wood that corresponds to the **potential heat requirements**.
- 9. Close the flue by-pass flap by pushing the handle (2) upwards.



Only refill with as much wood as the HDG Navora and accumulator can absorb as energy.

✓ The fuelling chamber is now full.

10. Close the top inside door (2).

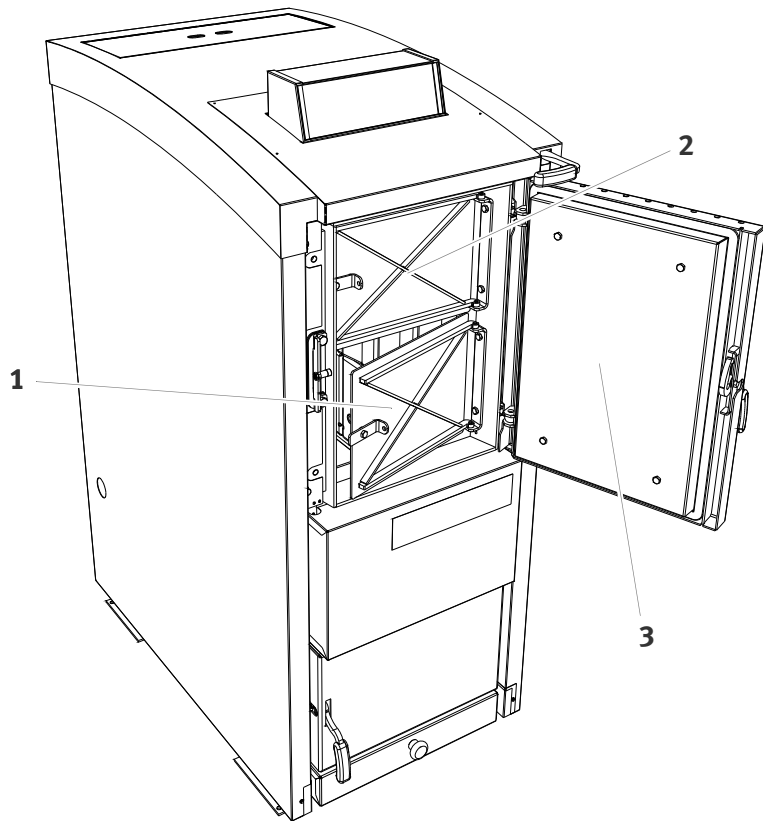

Figure 4/14 - Lighting and refuelling

11. Leave the lower inside door (1) ajar (100 to 150 mm) until the **“Heat production on”** message appears in the display and the **“Heat production on”** indicator lamp lights up.

✓ The **“Heat production on”** message in the display and the **“Heat production on”** indicator lamp appear when the required exhaust temperature is reached.

12. Close the lower inside door (1).

13. Close the outer filling hatch (3).

✓ The log wood boiler is now operating.

📖 See section **“3.4 Fuel quality requirements”** in chapter **“3 Functional description”**.

5 Cleaning and maintaining the HDG Navora

To ensure fault-free operation, certain cleaning and maintenance work is necessary. These avoid expensive repair work, as long as you maintain the recommended service intervals.

The biannual and longer term cleaning and maintenance work can be covered by a maintenance contract with an authorised heating engineer.

5.1 Cleaning and maintenance plan



The specified cleaning intervals are a guideline. Depending on the quality of the fuel and the power used by the HDG Navora, the intervals may be extended.

Interval	Component	see page ...
weekly / as required	• Removing ashes from the fuelling chamber and clean the burner nozzle	41
	• Removing ashes from the post-combustion chamber and ash compartment	43
Monthly (during the heating period, approx. 240 operating hours)	• Inspecting the heat exchanger cleaning system	45
Approx. 900 operating hours	• Check the flue and clean if necessary	47
	• Check the oxygen sensor and clean if necessary	48
	• Check the flue gas sensor and clean if necessary	49
	• Check the flue fan and clean if necessary	50
Annually (approx. 1800 operating hours)	• Check the primary and secondary air actuators	52
	• Inspect the integrity of the door seals	53
	• Clean the control panel	55
	• Calibrate the oxygen sensor	55
Biannually (approx. 3500 operating hours)	• Clean the panels and the primary air inlets	56

Table 5/1 - Cleaning and maintenance plan

5.2 How to proceed



Warning!

Danger of asphyxiation due to carbon monoxide.

If the boiler is operating, carbon monoxide can be emitted through open combustion chamber doors.

Do not leave the combustion chamber doors open any longer than necessary.



The operating status of the HDG Navora must be indicated with “Heat production off” in the display of the HDG Lambda Control.

See section “4.1 Overview of the controls and display components” in chapter “4 Using the HDG Navora Wood Boiler”



Caution!

Danger of burns from hot surfaces.

When operating, the boiler surfaces under the cladding are hot. Even when turned off, they only cool down slowly.

Only touch the hot surfaces while wearing protective clothing or wait until the surfaces have cooled down before starting with the cleaning and maintenance work.



Caution!

Danger of fire

Working in areas marked with this symbol can lead to a fire.

CLEANING TOOLS

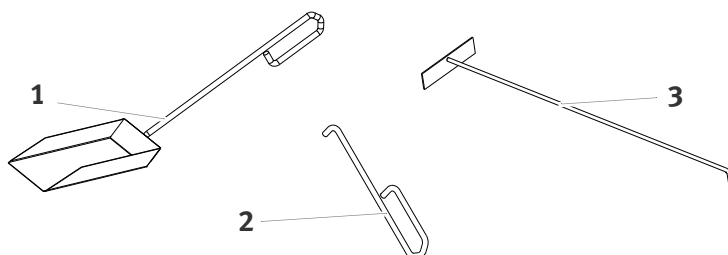

Figure 5/1 - Supplied cleaning tools

- 1 Ash shovel
- 2 Door opening tool (inside doors)
- 3 Poker

INSPECTING THE HEAT EXCHANGER CLEANING SYSTEM

1. Allow the fire in the boiler to burn out.



The operating status of the HDG Navora must be indicated with “**Heat production off**” in the display of the HDG Lambda Control.

See section “4.1 Overview of the controls and display components” in chapter “4 Using the HDG Navora Wood Boiler”.

**Caution!**

Danger of burns from hot surfaces.

The surfaces of the boiler can be hot. Even when turned off, they only cool down slowly.

Do not start with the maintenance work until the surfaces have cooled down.



2. Press the “*Refill*” button.

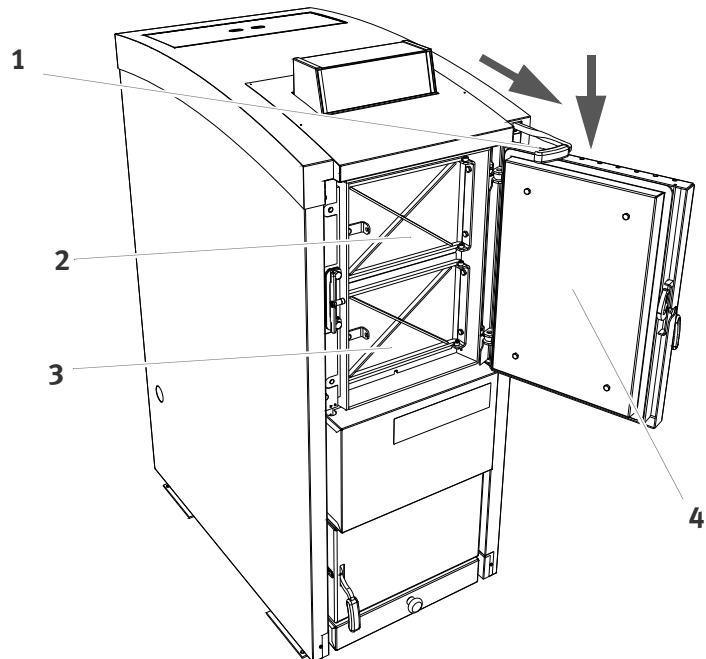

Figure 5/2 -

3. Open the outer fuelling chamber door (4).
4. Open the flue by-pass flap.
5. Open the top inside door (2) first, and the the lower inside door (3).

6. Use the supplied cleaning tools to remove loose ash from the fuelling chamber (1).
7. Leave any unburnt pieces of wood and charcoal in the refuelling chamber (1).
8. Remove the burner nozzle (2).

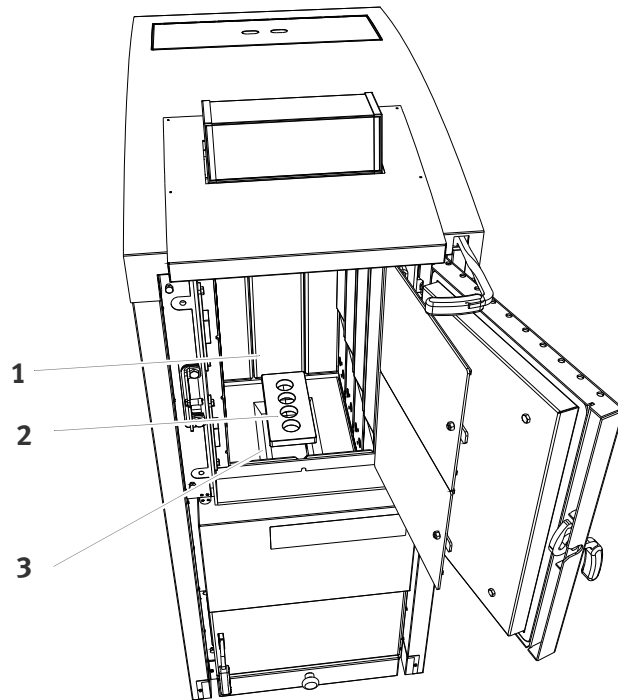

Figure 5/3 - Cleaning the stationary grate

9. Clean the secondary air inlets (4) with a suitable vacuum cleaner.

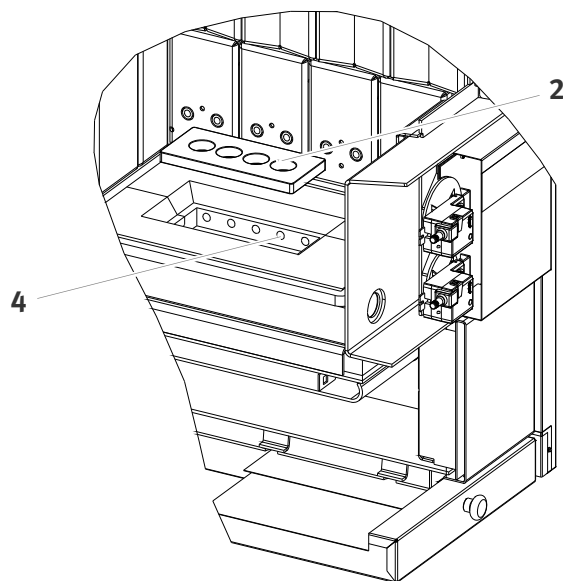

Figure 5/4 - Cleaning the ash compartment

10. Reinsert the burner nozzle (2).
11. Close the fuelling chamber door doors in reverse order.

**Caution!****Danger of fire**

Do not suck up hot ashes with the vacuum!

✓ The fuelling chamber and the burner nozzle are clean.

REMOVING ASHES FROM THE POST-COMBUSTION CHAMBER AND ASH COMPARTMENT

1. Allow the fire in the boiler to burn out.



The operating status of the HDG Navora must be indicated with “**H**eat **p**roduction **o**ff” in the display of the HDG Lambda Control.

 See section “4.1 Overview of the controls and display components” in chapter “4 Using the HDG Navora Wood Boiler”.

**Caution!**

Danger of burns from hot surfaces.

The surfaces of the boiler can be hot. Even when turned off, they only cool down slowly.

Do not start with the maintenance work until the surfaces have cooled down.



Press the “*Refill*” button.

**Caution!****Danger of fire**

Do not suck up hot ashes with a vacuum!

2. Pull out the ash drawer approx. 300 mm.

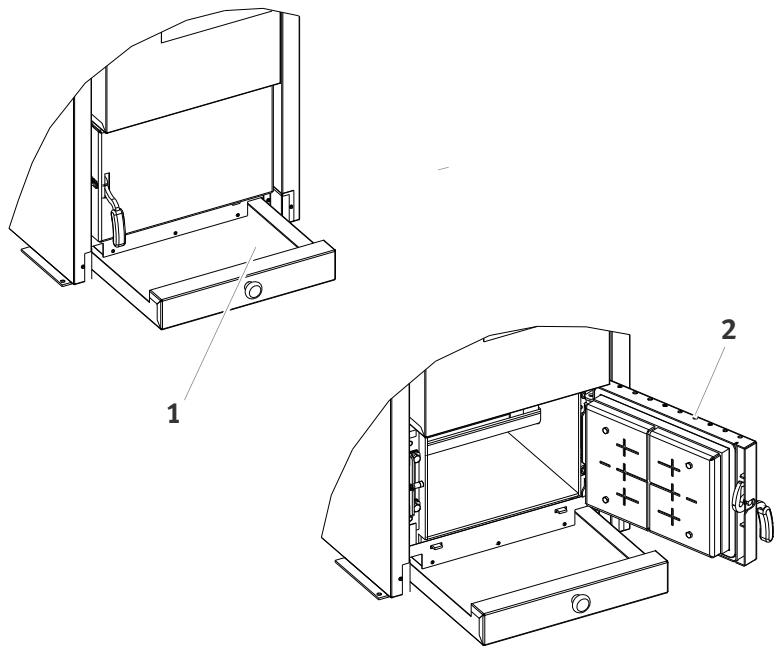

Figure 5/5 - Cleaning the ash compartment

3. Open the combustion chamber door (2).
4. Use the supplied cleaning tools to pull the combustion residues out of the combustion chamber (1) and the ash compartment (3), and into the ash drawer (2).

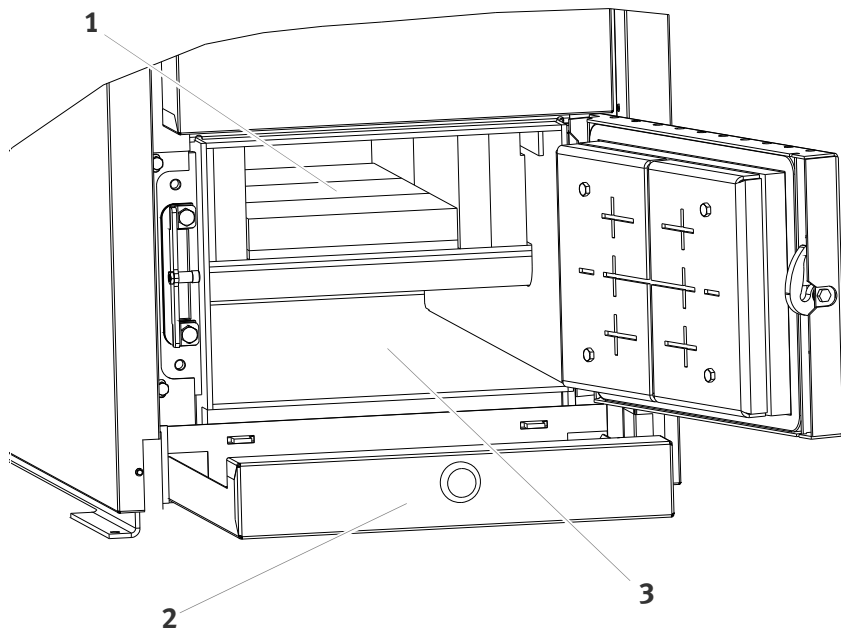

Figure 5/6 - Cleaning the ash compartment

5. Empty the ashes into a fireproof container.

**Caution!****Danger of fire**

Place hot ashes in a fireproof container!

6. Reinsert the ash drawer and close the combustion chamber in reverse order.
- ✓ The post-combustion chamber and the ash compartment are clean again.

INSPECTING THE HEAT EXCHANGER CLEANING SYSTEM

1. Allow the fire in the boiler to burn out.



The operating status of the HDG Navora must be indicated with “**Heat production off**” in the display of the HDG Lambda Control.

- 📎 See section “4.1 Overview of the controls and display components” in chapter “4 Using the HDG Navora Wood Boiler”.

**Caution!**

Danger of burns from hot surfaces.

The surfaces of the boiler can be hot. Even when turned off, they only cool down slowly.

Do not start with the maintenance work until the surfaces have cooled down.

2. Disconnect the plug for the power supply to the flue fan (4).

3. Remove the top cover plate (1).

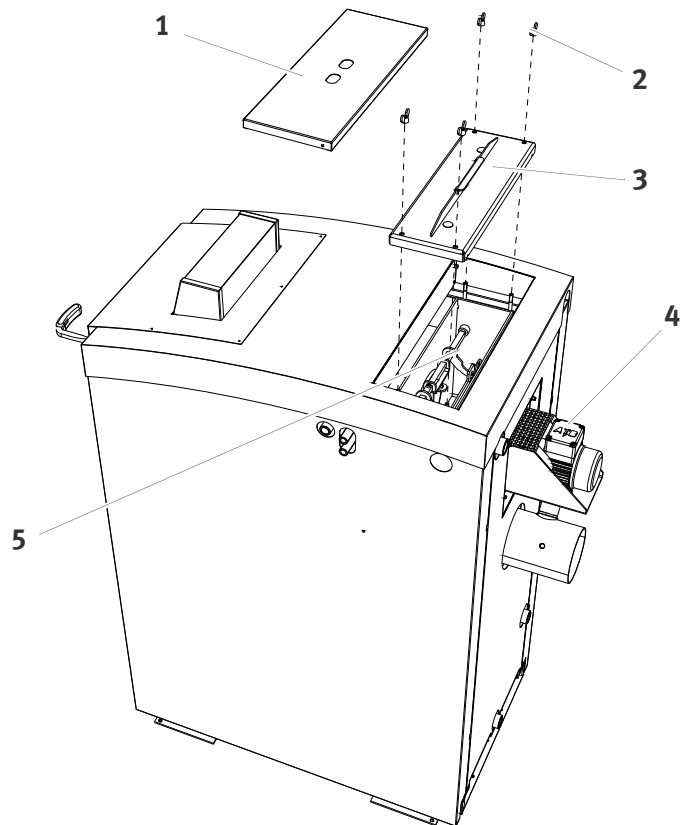

Figure 5/7 - Cleaning the burner nozzle

4. Unscrew the four M 8 wing nuts (2).
5. Pull the inspection hatch (3) up and out.
6. Inspect the cleaning system (5) for deposits.
7. If necessary, remove deposits and dust with a suitable vacuum cleaner.



Caution!

Danger of fire

Be careful not to suck any hot ashes into the vacuum cleaner.

8. Close the cleaning system in reverse order.
 9. Reconnect the plug for the power supply to the flue fan (4).
- ✓ The cleaning system has been inspected.

CHECK THE FLUE AND CLEAN IF NECESSARY

1. Allow the fire in the boiler to burn out.



The operating status of the HDG Navora must be indicated with “**Heat production off**” in the display of the HDG Lambda Control.

 See section “4.1 Overview of the controls and display components” in chapter “4 Using the HDG Navora Wood Boiler”.

**Caution!**

Danger of burns from hot surfaces.

The surfaces of the boiler can be hot. Even when turned off, they only cool down slowly.

Do not start with the maintenance work until the surfaces have cooled down.

2. Allow the boiler and the flue (3) to cool down.
3. Unscrew the wing nut (1) on the inspection hatch (2).
4. Remove the inspection hatch (2) from the flue (3).
5. Check whether the flue needs cleaning.
6. If necessary, use a suitable vacuum cleaner to clean out the flue (3).
7. Slide any deposits into the flue gas collection box, but not in the direction of the boiler.

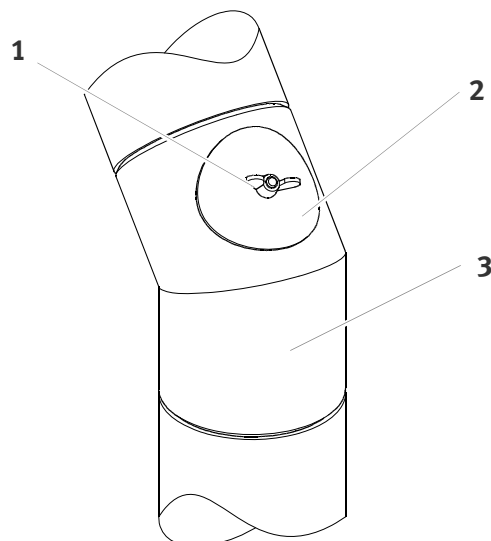

Figure 5/8 - Cleaning the flue

8. Refit the inspection hatch (2) firmly onto the flue pipe (3) using the wing nut (1).

✓ The flue pipe is clean.

CHECK THE OXYGEN SENSOR AND CLEAN IF NECESSARY

1. Allow the fire in the boiler to burn out.



The operating status of the HDG Navora must be indicated with “**H**eat **p**roduction **o**ff” in the display of the HDG Lambda Control.

See section “4.1 Overview of the controls and display components” in chapter “4 Using the HDG Navora Wood Boiler”.



Caution!

Danger of burns from hot surfaces.

The surfaces of the boiler can be hot. Even when turned off, they only cool down slowly.

Do not start with the maintenance work until the surfaces have cooled down.

2. Unscrew the union nut (1) with a pipe wrench.

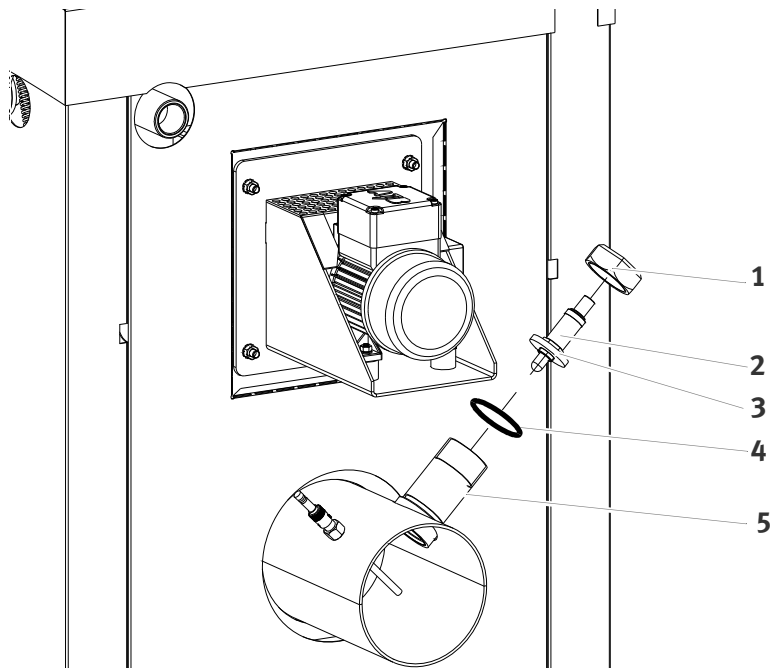

Figure 5/9 - Cleaning the oxygen sensor

3. Remove the oxygen sensor (2), including the insulating disc (3) and the seal (4), from the installation fitting (5).
4. Brush off the oxygen sensor (2) with a **brass brush**.



Do not use steel bristles!

Steel bristles will **damage** the oxygen sensor.

5. Clean out any deposits found inside the installation fitting (5).
6. Reinstall the oxygen sensor (2) in reverse order.



Tightness

When reinstalling the oxygen sensor, make sure it is firmly tightened.

Use a pipe wrench to tighten the union nut (1). Do not over tighten!
Never tighten the oxygen sensor by the shaft body.

✓ The oxygen sensor is clean.

INSPECTING AND CLEANING THE FLUE GAS SENSOR

1. Allow the fire in the boiler to burn out.



The operating status of the HDG Navora must be indicated with “**Heat production off**” in the display of the HDG Lambda Control.

✎ See section “4.1 Overview of the controls and display components” in chapter “4 Using the HDG Navora Wood Boiler”.



Caution!

Danger of burns from hot surfaces.

The surfaces of the boiler can be hot. Even when turned off, they only cool down slowly.

Do not start with the maintenance work until the surfaces have cooled down.

2. Using light pressure, rotate the flue gas sensor (1) downwards one quarter turn in an anticlockwise direction.

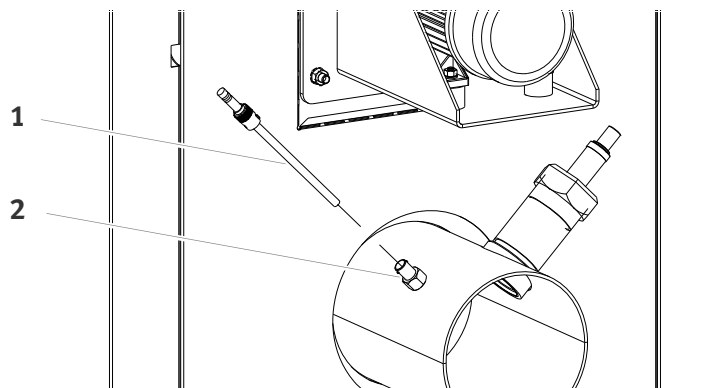

Figure 5/10 - Cleaning the flue sensor

3. Pull the flue sensor (1) out of the holder (2).

4. Clean the sensor.

5. Reinstall the flue sensor (1) in reverse order.

✓ The flue sensor is cleaned.

INSPECTING AND CLEANING THE FLUE FAN

1. Allow the fire in the boiler to burn out.



The operating status of the HDG Navora must be indicated with “**H**eat **p**roduction **o**ff” in the display of the HDG Lambda Control.

 See section “4.1 Overview of the controls and display components” in chapter “4 Using the HDG Navora Wood Boiler”.



Caution!

Danger of burns from hot surfaces.

The surfaces of the boiler can be hot. Even when turned off, they only cool down slowly.

Do not start with the maintenance work until the surfaces have cooled down.



Caution!

Hand injuries

Working in areas marked with this symbol can lead to hand injuries.

2. Disconnect the plug (2) from the flue fan (3).
3. Use a hand ratchet to unscrew the four M8 nuts (1).

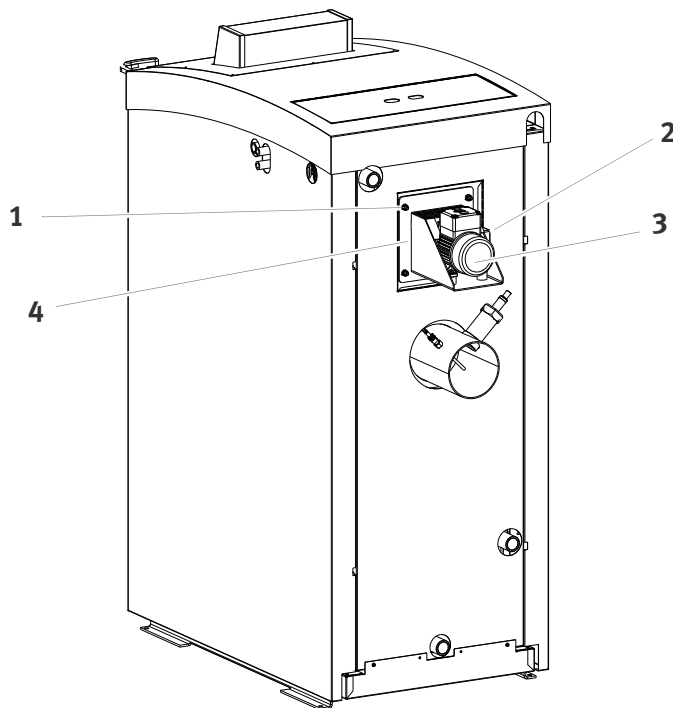

Figure 5/11 - Cleaning the flue fan

4. Remove the exhaust blower (3), including the flange plate (4), from the boiler.

5. Clean the flue gas collection box (1).

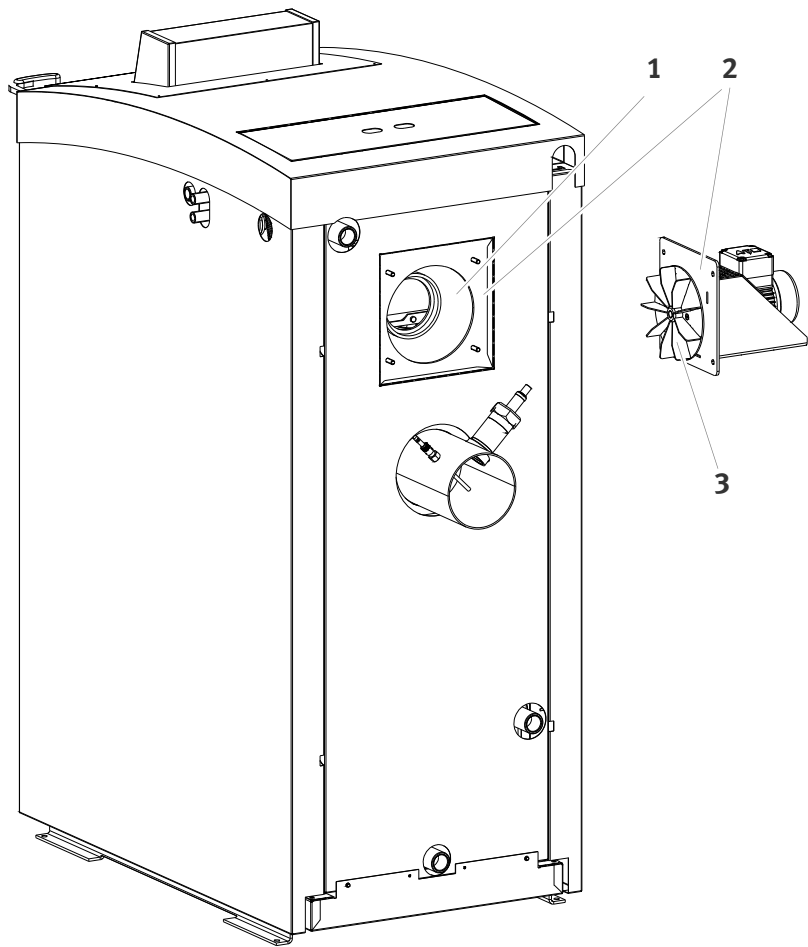

Figure 5/12 - Cleaning the flue fan

6. Clean the impeller (3) with a brass brush.
 7. Clean the flue fan also between the impeller (3) and the mounting plate of the flue fan (2).
 8. Inspect the seal and the contact surfaces around the flue fan (2) and the flue gas collection box (1).
 9. Replace the seal if it is damaged.
 10. Reinstall the flue fan in reverse order.
- ✓ The flue fan is clean again.

CHECK THE PRIMARY AND SECONDARY AIR ACUATORS

1. Allow the fire in the boiler to burn out.



The operating status of the HDG Navora must be indicated with “**H**eat **p**roduction **o**ff” in the display of the HDG Lambda Control.

 See section “4.1 Overview of the controls and display components” in chapter “4 Using the HDG Navora Wood Boiler”.



Caution!

Danger of burns from hot surfaces.

The surfaces of the boiler can be hot. Even when turned off, they only cool down slowly.

Do not start with the maintenance work until the surfaces have cooled down.

2. Lift up on the cladding (2) which covers the actuators (1) and pull it out towards.

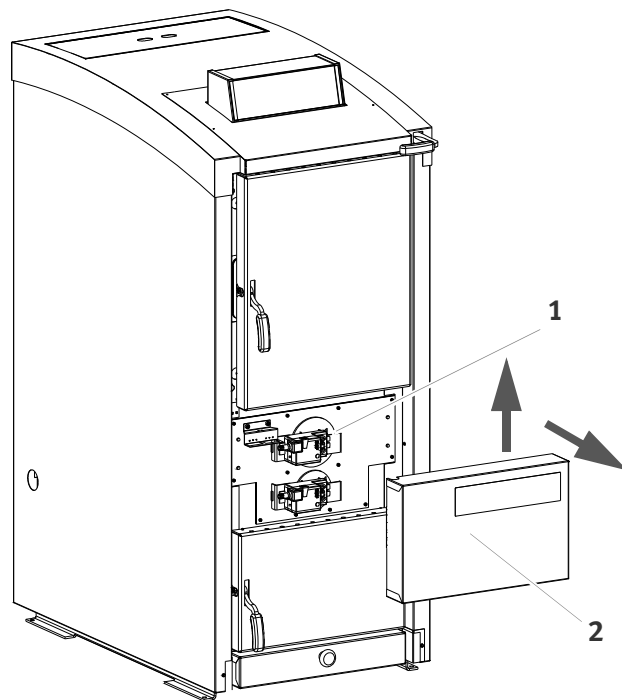

Figure 5/13 - Inspecting the door seals

3. Use a fine brush and a vacuum cleaner to remove dust deposits from the actuators and surrounding area (1).
 4. Reinsert the actuator cover in reverse order.
- ✓ The actuator units are now clean.

INSPECT THE FUELLING
CHAMBER DOOR

INSPECTING THE INTEGRITY OF THE DOOR SEALS

1. Allow the fire in the boiler to burn out.



The operating status of the HDG Navora must be indicated with “Heat production off” in the display of the HDG Lambda Control.

See section “4.1 Overview of the controls and display components” in chapter “4 Using the HDG Navora Wood Boiler”.

**Caution!**

Danger of burns from hot surfaces.

The surfaces of the boiler can be hot. Even when turned off, they only cool down slowly.

Do not start with the maintenance work until the surfaces have cooled down.



2. Press the “Refill” button.
3. Open the fuelling chamber door (2)
4. Clamp a sheet of paper (approx. 300 mm long and 40 mm wide) between the contact surface (1) and the seal (3).
5. Close the fuelling chamber door (2).
6. Pull on the paper.

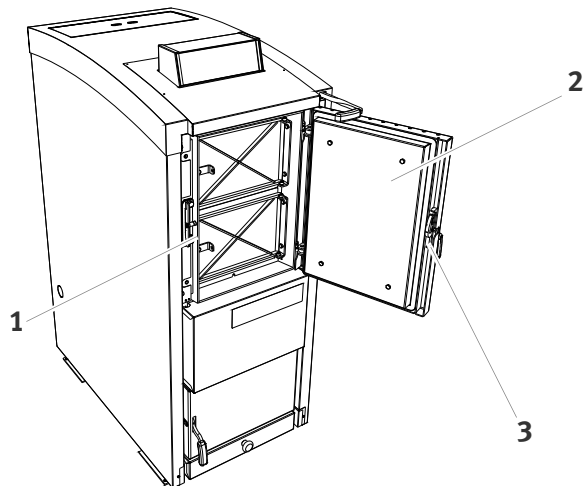

Figure 5/14 - Inspecting the door seals

- ✓ If the paper moves, the door is not properly sealed.
- ✓ If the paper does not move, the door is properly sealed.



If the fuelling chamber door does not seal properly, contact a specialist to have it repaired.

7. Repeat the procedure from step 2 to step 5 until you have inspected all four of the contact surfaces (1).

INSPECTING THE
COMBUSTION CHAMBER
DOOR

8. Remove the paper and close the fuelling chamber door (2).

✓ The fuelling chamber door seal has been checked.

1. Allow the fire in the boiler to burn out.



The operating status of the HDG Navora must be indicated with “**H**eat **p**roduction **o**ff” in the display of the HDG Lambda Control.

See section “4.1 Overview of the controls and display components” in chapter “4 Using the HDG Navora Wood Boiler”.



Caution!

Danger of burns from hot surfaces.

The surfaces of the boiler can be hot. Even when turned off, they only cool down slowly.

Do not start with the maintenance work until the surfaces have cooled down.



2. Press the “*Refill*” button.

3. Open the combustion chamber door (2).

4. Clamp a sheet of paper (approx. 300 mm long and 40 mm wide) between the contact surface (1) and the seal (3).

5. Close the combustion chamber door (2).

6. Pull on the paper.

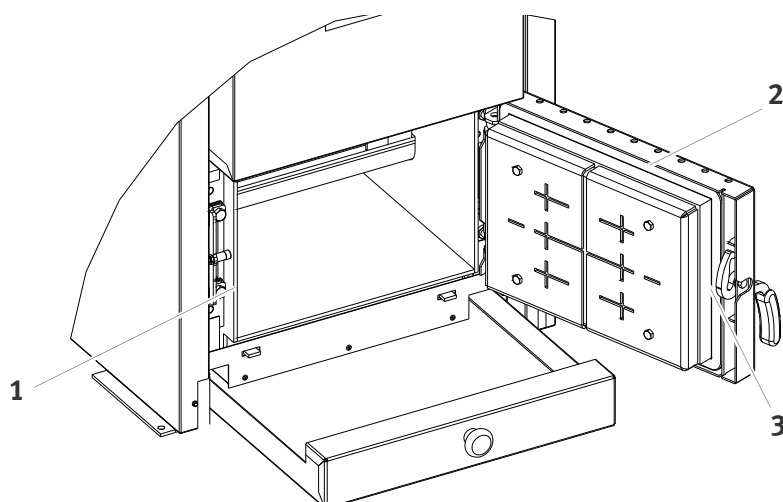

Figure 5/15 - Inspecting the door seals

✓ If the paper moves, the door is not properly sealed.

✓ If the paper does not move, the door is properly sealed.



If the combustion chamber door does not seal properly, contact a specialist to have it repaired.

7. Repeat the procedure from step 2 to step 5 until you have inspected all four of the contact surfaces (1).
 8. Remove the paper and close the combustion chamber door (2).
- ✓ The combustion chamber door seal has been checked.

CLEAN THE CONTROL PANEL

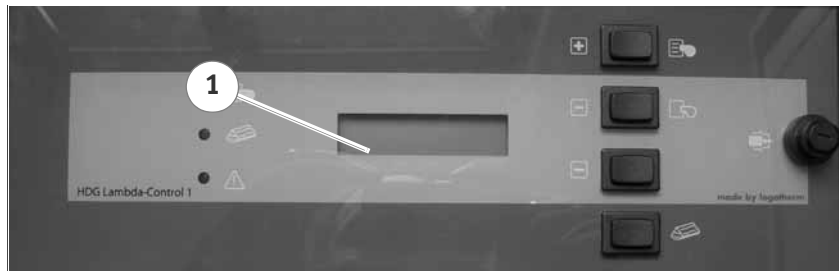

Figure 5/16 - HDG Lambda Control 1 control panel

1. Clean the control unit with a moist, lint-free cloth.
 2. For stubborn dirt, use a mild cleaning agent.
 3. Dry the control unit with a soft cloth.
- ✓ The control unit is clean.

CALIBRATE THE OXYGEN SENSOR

1. Allow the fire in the boiler to burn out.



The operating status of the HDG Navora must be indicated with **“Heat production off”** in the display of the HDG Lambda Control.

There can not be any residual embers in the fuelling chamber!

📎 See section “4.1 Overview of the controls and display components” in chapter “4 Using the HDG Navora Wood Boiler”.



2. Press the *Arrow* button.

✓ The **“Selection/information”** message will appear in the display.



3. Press the *Plus* button twice.

✓ The **“Testing system components”** message will appear in the display.



4. Press the *Arrow* button.

✓ The **“Test O₂ sensor”** message will appear in the display.



5. Press the *Plus* button.

✓ The calibration of the oxygen sensor starts. The runtime is **720** seconds.

- ✓ When the sensor test is complete, the “**Sensor okay**” message will appear in the display.
- ✓ The oxygen sensor is calibrated.



If the “**Sensor defective**” message appears in the display, have the fault rectified by a qualified electrician or an authorised HDG installer.



6. Press the *Plus* and *Minus* buttons simultaneously.

- ✓ The system component test is complete.

CLEAN THE PANELS AND THE PRIMARY AIR INLETS

1. Allow the fire in the boiler to burn out.



The operating status of the HDG Navora must be indicated with “**Heat production off**” in the display of the HDG Lambda Control.

 See section “4.1 Overview of the controls and display components” in chapter “4 Using the HDG Navora Wood Boiler”.



Caution!

Danger of burns from hot surfaces.

The surfaces of the boiler can be hot. Even when turned off, they only cool down slowly.

Do not start with the maintenance work until the surfaces have cooled down.



2. Press the “*Refill*” button.

3. Open the fuelling chamber door (2) and the inside doors (1).

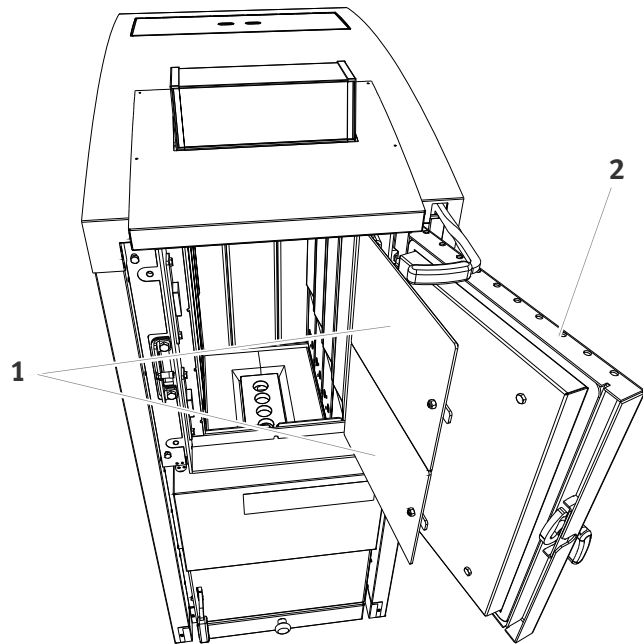

Figure 5/17 - Cleaning the primary and secondary air ducts

4. Lift up on the top inside panel.

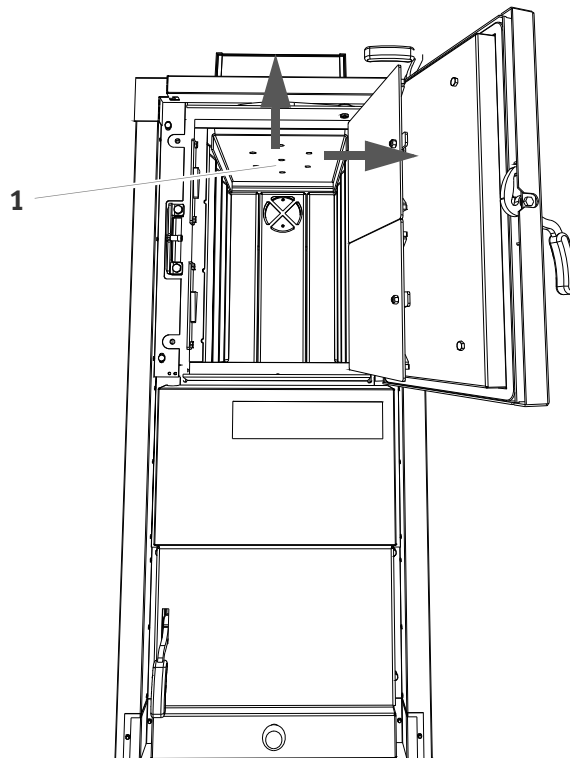

Figure 5/18 - Cleaning the primary and secondary air ducts

5. Slide the panel (1) towards the right.

6. Fold down the panel (1) at the left side and remove it.

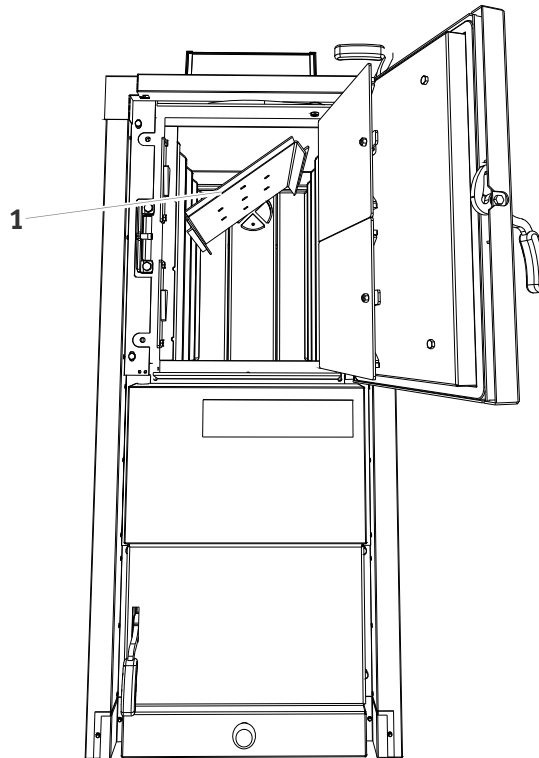

Figure 5/19 - Cleaning the primary and secondary air ducts

7. Lift all upper panels (1) out of the holder.

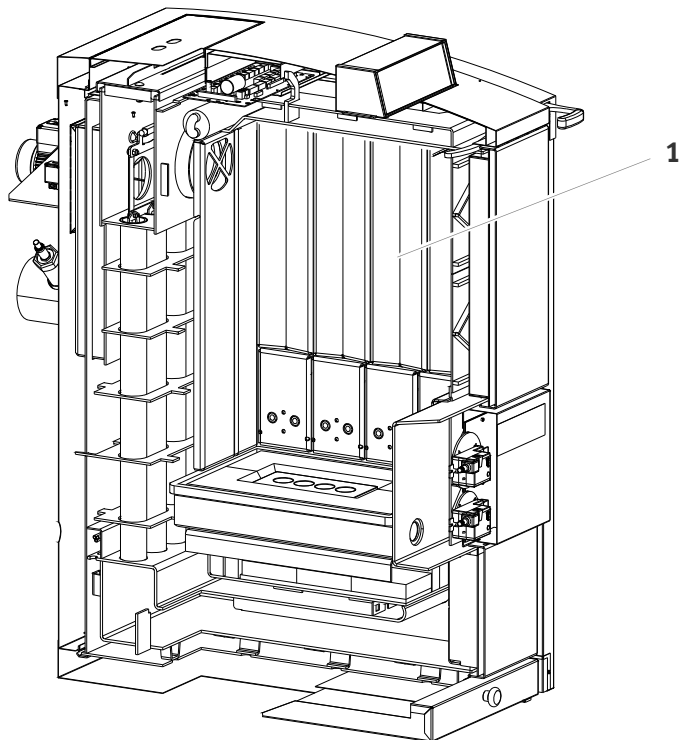

Figure 5/20 - Cleaning the primary and secondary air ducts

8. Lift all lower panels (2) out of the holder.

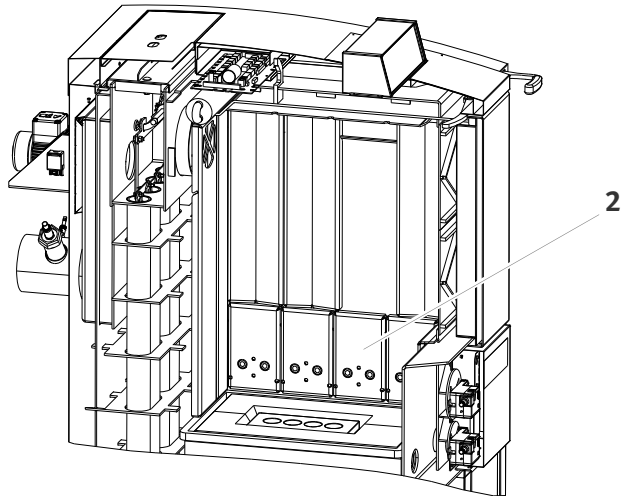

Figure 5/21 - Cleaning the primary and secondary air ducts

9. Clean all of the primary air inlets (3) and the panels with a wire brush and a vacuum cleaner.

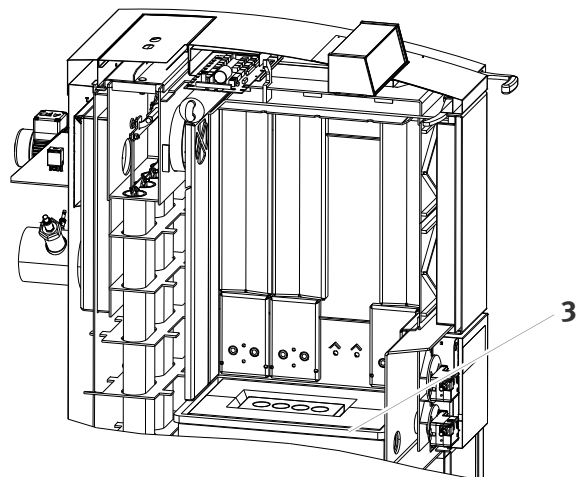

Figure 5/22 - Cleaning the primary and secondary air ducts

10. Reinstall the panels in reverse order.
11. Close the boiler.
- ✓ The panels and the primary air inlets are clean again.

6 Troubleshooting

If a fault occurs in the HDG Navora, it will be indicated in the display of the HDG Lambda Control 1 and the by the indicator lamp on the HDG Lambda Control 1 control panel.

Faults are broken down into two types:

- Faults which permit the heating process to continue
 - The fault indicator lamp on the control panel of the HDG Lambda Control 1 blinks
- Faults which do not permit the heating process to continue
 - The fault indicator lamp on the control panel of the HDG Lambda Control 1 lights up (stays on and does not blink)

 See section “4 Using the HDG Navora Wood Boiler” in chapter “Control panel HDG Lambda Control 1”

6.1 How to proceed

1. Look for the displayed fault, its cause and remedy in Table 6/1 - Faults with blinking indicator lamp.
 2. Fix the fault, or have it fixed by an authorised electrician.
 3. Acknowledge the fault with the *Arrow* button.
- ✓ The fault will be cleared from the display.



6.2 Possible faults

FAULTS WHICH DO NOT INTERRUPT THE PRODUCTION OF HEAT

The fault indicator lamp on the control panel of the HDG Lambda Control 1 blinks.

Fault message	Cause	Remedy
<p>Incorrect oxygen level reading</p> <p>Sensor is worn out or needs cleaning</p> <p>Plug/conductor</p> <p>Controller is faulty</p>	<ul style="list-style-type: none"> Oxygen sensor is worn out or needs cleaning 	<ul style="list-style-type: none"> Clean and calibrate the oxygen sensor See chapter “5 Cleaning and maintaining the HDG Navora” Can only be reset by calibrating
<p>Incorrect tank (accumulator) temperature reading</p> <p>Plug/conductor</p> <p>Sensor is faulty</p> <p>Controller is faulty</p>	<ul style="list-style-type: none"> Sensor is faulty Contact is open Controller is faulty 	<ul style="list-style-type: none"> Have the fault fixed by an authorised installer Automatically reset after fault is remedied
<p>Incorrect return temperature reading</p> <p>Plug/conductor</p> <p>Sensor is faulty</p> <p>Controller is faulty</p> <p>(For system 5 only)</p>	<ul style="list-style-type: none"> Sensor is faulty Contact is open Controller is faulty 	<ul style="list-style-type: none"> Have the fault fixed by an authorised installer Automatically reset after fault is remedied
<p>Boiler temperature too low</p> <p>Return valve</p> <p>Plug/conductor</p> <p>Motor/controller</p>	<ul style="list-style-type: none"> Sensor is faulty Contact is open Controller is faulty Return valve 	<ul style="list-style-type: none"> Have the fault fixed by an authorised installer Reset by pressing the <i>Arrow</i> button

Table 6/1 - Faults with blinking indicator lamp

FAULTS WHICH INTERRUPT THE PRODUCTION OF HEAT

The fault indicator lamp on the control panel of the HDG Lambda Control 1 lights up (but does not blink).

Fault message	Cause	Remedy
STB is triggered - reset Insufficient heat extraction! Pumps/valves	<ul style="list-style-type: none"> • Safety temperature limiter triggered 	<ul style="list-style-type: none"> • Have the fault fixed by an authorised installer
Incorrect exhaust temperature reading Plug/conductor Sensor is faulty Controller is faulty	<ul style="list-style-type: none"> • Sensor is faulty • Contact is open • Controller is faulty (exhaust temperature above 300 °C, cleaning door open, door seal defective, fire in flue) 	<ul style="list-style-type: none"> • Have the fault fixed by an authorised installer
Incorrect boiler temperature reading Plug/conductor Sensor is faulty Controller is faulty	<ul style="list-style-type: none"> • Sensor is faulty • Contact is open • Controller is faulty 	<ul style="list-style-type: none"> • Have the fault fixed by an authorised installer
Data loss Controller is faulty	<ul style="list-style-type: none"> • Controller is faulty 	<ul style="list-style-type: none"> • Have the fault fixed by an authorised installer

Table 6/2 - Faults which cause indicator lamp to stay on

7 Commissioning the HDG Navora

The HDG Navora will initially be commissioned by specialists from HDG Bavaria or from an authorised HDG partner.

The commissioning includes an introduction to the operation and maintenance of the HDG Navora as well as the taking of measurements on the system for pollution and heating capacity.



Danger!

Material damage and injury due to incorrect commissioning.

Commissioning the system requires comprehensive specialist knowledge. If this commissioning is done by an untrained person, the HDG Navora can be damaged.

Only allow authorised specialists to do the commissioning.

7.1 Conditions

The following requirements must be met to ensure there are no problems during commissioning.









- The HDG Navora has been filled with water as specified.
- The HDG Navora has been deaerated.
- The pressure of the membrane expansion container has been adapted to on-site conditions.
- All required BS EN 12828 safety devices have been installed and are ready for operation.
- The supply of power to all components has been provided (makeshift solutions are not sufficient).
- All doors and access areas on the boiler and on the chimney connection duct have been checked for a proper seal.
- Air supply for combustion has been provided.
- A sufficient amount of fuel is available.

7.2 Commissioning the HDG Navora

SWITCHING HDG NAVORA ON

1. Switch on the fused spur in the mains supply.
2. Switch on the emergency heating switch (if one has been installed).
- ✓ There is now electrical power in the HDG Navora.
- ✓ The indicator light in the emergency heating switch will light up.
- ✓ The control is activated.
- ✓ The controller self test is activated.
- ✓ The “**Enter code**” message will appear in the display.

CONFIGURING THE CONTROL

- | | | |
|------------------|---|---|
| LANGUAGE | 
 | <ol style="list-style-type: none"> 1. Press the <i>Plus</i> button. ✓ The value of the displayed code will be increased by one. 2. Confirm the value with the <i>Arrow</i> button. ✓ The “Language [D] Deutsch” message will appear in the display. |
| BOILER TYPE | 

 | <ol style="list-style-type: none"> 3. Use the <i>Plus</i> or <i>Minus</i> button to select the desired language. ✓ The selected language will appear in the display. 4. Use the <i>Arrow</i> button to confirm your entry. ✓ The language is set and the menu will advance to the next setting. ✓ The “Boiler type HDG Navora..” message will appear in the display. 5. Read the boiler type from the name plate on the boiler. 6. Use the <i>Plus</i> or <i>Minus</i> button to select the appropriate boiler type. ✓ The selected boiler type will appear in the display. 7. Use the <i>Arrow</i> button to confirm your entry. ✓ The boiler type is set and the menu will advance to the next setting. ✓ The following message will appear in the display, “System no.: 0”. |
| HYDRAULIC SYSTEM | 

 | <ol style="list-style-type: none"> 8. Use the <i>Plus</i> or <i>Minus</i> button to select the appropriate hydraulic system. ✓ The selected hydraulic system will appear in the display. 9. Use the <i>Arrow</i> button to confirm your entry. |



Refer to the planning and installation documentation to determine the specific hydraulic system.

✓ The “**Are you sure?**” message will appear in the display.



10. Press the *Arrow* button to confirm your selection.

✓ The hydraulic system is set and the menu will advance to the next setting.



11. Press the *Minus* button to change the selected hydraulic system.

✓ The menu will return to the selection window for the hydraulic system.

12. Select another hydraulic system and proceed as instructed in **Step 10**.

✓ The hydraulic system is set and the menu will advance to the next setting.

✓ The “**Accumulator sensor: yes?**” message will appear in the display.

ACCUMULATOR SENSOR



13. Use the *Plus* or *Minus* button to select the setting “**Yes**” or “**No**”.

✓ The selected setting will appear in the display.



14. Use the *Arrow* button to confirm your entry.

✓ The setting is stored and the menu will advance to the next setting.



“**Accumulator sensor in [m] 8**” will only appear if the “**Accumulator sensor: yes**” setting was selected.

CABLE LENGTH OF THE ACCUMULATOR SENSOR

✓ The “**Accumulator sensor length in [m] 8**” message will appear in the display.



15. Use the *Plus* or *Minus* button to select the actual cable length to ensure that the correct value will be obtained for temperature readings.

✓ The corresponding value will appear in the display.



16. Use the *Arrow* button to confirm your entry.

✓ The cable length is set and the menu will advance to the next setting.

MINIMUM ACCUMULATOR TEMPERATURE

✓ The “**Min. tank TS [°C] 45**” message will appear in the display.



17. Use the *Plus* or *Minus* button to select the desired minimum accumulator temperature for load balancing, accumulator or energy store.



If the preset minimum temperature is not achieved, the “**Refill**” indicator is activated and the oil or gas burner is switched on (for hybrid systems).

MINIMUM BOILER TEMPERATURE



✓ The selected minimum accumulator temperature will appear in the display.

18. Use the *Arrow* button to confirm your entry.

✓ The minimum accumulator temperature is set and the menu will advance to the next setting.

✓ The “**Min. boiler TK** [°C] 60” message will appear in the display.



The “Minimum boiler temperature” should not be set to less than 60 °C.



19. Use the *Plus* or *Minus* button to select the required “minimum boiler temperature”.

✓ The selected temperature will appear in the display.



20. Use the *Arrow* button to confirm your entry.

The setting is stored and the menu will advance to the next setting.

✓ The “**Min. exhaust temperature/** TA_{min} [°C] 100” message will appear in the display.

MINIMUM EXHAUST TEMPERATURE



This value is the required lowest temperature setting for the chimney. Observe the specifications provided by the chimney manufacturer and/or installer.



21. Use the *Plus* or *Minus* button to select the appropriate minimum exhaust temperature.

✓ The selected temperature will appear in the display.



22. Confirm the minimum exhaust temperature setting with the *Arrow* button.

✓ The minimum exhaust temperature is set and the menu will advance to the next setting.

✓ The “**Return valve** [sec.] 150” message will appear in the display.

RETURN VALVE RUNTIME



23. Use the *Plus* or *Minus* button to select the runtime for the installed servo drive for the return valve.



Please note!

Setting range 120 - 240 seconds.

✓ The selected runtime will appear in the display.



24. Use the *Arrow* button to confirm your entry.

✓ The runtime is set and the menu will advance to the next setting.

✓ The “**Charging valve** [sec.] 150” message will appear in the display.

CHARGING VALVE RUNTIME



25. Use the *Plus* or *Minus* button to select the runtime for the installed servo drive for the charging valve.



Please note!

Setting range 120 - 240 seconds.

✓ The selected runtime will appear in the display.



26. Use the *Arrow* button to confirm your entry.

✓ The basic settings have been set. The display will revert back to the standard display mode, which alternately indicates the operating status and the boiler temperature.

SETTING THE TARGET BOILER TEMPERATURE



1. Press the *Arrow* button.

✓ The **SELECTION** and **INFORMATION** message will appear in the display.



2. Press the *Plus* button.

✓ The **SELECTION** and **SETTINGS** message will appear in the display.



3. Press the *Arrow* button.

✓ **Target boiler temperature TK S [°C]** will appear in the display.



4. Use the *Arrow* button to select parameters.

✓ The value will blink in the display.



5. Use the *Plus* or *Minus* button to increase or decrease the value up to 82 ° C (factory default 80 ° C).



6. Confirm the input value with the *Arrow* button.

✓ The boiler target temperature is set.

 See section “4.3 Structure of the menu” in chapter “4 Using the HDG Navora Wood Boiler”.

✓ The HDG Lambda Control 1 control system has been set-up for your system and is ready for operation.

7. Record the data and set values in the following table so that the parameters are readily available in case service is needed.

CUSTOMER DATA

Customer data	
Customer's name	
Street	
Postcode/city	
Telephone	
Boiler type	HDG Navora kW
Boiler number	

Table 7/1 - Customer data

MEMORANDUM FOR SET VALUES

Setting description	Standard configuration	Alternative settings
Language	• GB	
Hydraulic system (electrical connection)	• 0	
Accumulator sensor	• Yes	
Accumulator sensor length in [m]	• 8 m	
Minimum accumulator temperature TS_{min} [°C]	• 45 °C	
Minimum boiler temperature TK_{min} [°C]	• 60 °C	
Minimum exhaust temperature TA_{min} [°C]	• 100 °C	
Return valve runtime [sec]	• 150 sec.	
Charging valve runtime [sec]	• 150 sec.	

Table 7/2 - Set values

TESTING SYSTEM COMPONENTS



Caution!

For safety reasons, the system component test may only be conducted when there is no fuel in the boiler and there are no remaining embers.



Please note!

Test can only be conducted in "Heat production off" mode.

HOW TO PROCEED



The respective test is initiated by pressing the *Plus* button.



The respective test is stopped by pressing the *Minus* button.



The test is conducted on the next component by pressing the *Arrow* button.



The component test is stopped by simultaneously pressing the *Plus* and *Minus* buttons.



1. Press the *Arrow* button.

✓ The "Selection/information" message will appear in the display.



2. Press the *Plus* button.

✓ The display changes to **Selection/settings**.



3. Press the *Plus* button again.

✓ The display changes to **Selection/component test**.



4. Press the *Arrow* button.

✓ The **O2 sensor test** message will appear in the display.



5. Press the *Plus* button.

✓ The O2 sensor test will begin. (**Duration = 720 seconds**)

🔗 See the paragraph "Calibrate the oxygen sensor" in section "5.2 How to proceed" in the chapter "5 Cleaning and maintaining the HDG Navora".

✓ The O2 sensor test is complete.



6. Press the *Arrow* button.

✓ The display advances to the next component: **primary pump**.

7. Now conduct the test according to steps listed above for each individual component in the order listed below.

The component testing sequence is as follows.

- Return valve (Y1)
The switch (1) of the servo motor has to be moved in the position as shown in figure 7/1.

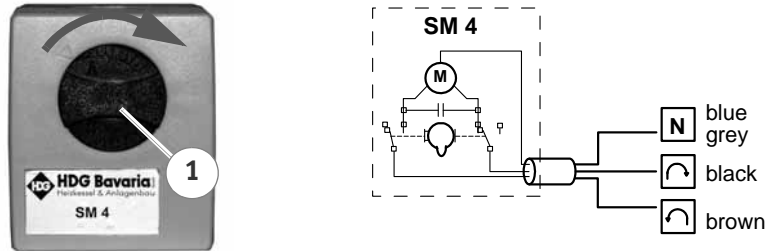

Figure 7/1 - Switch servo motor

To change the direction of rotation the black and the brown wire at the servo motor have to be swapped.
The closed door (1) is shown by groove (2) at the axle of the return Valve Y1.

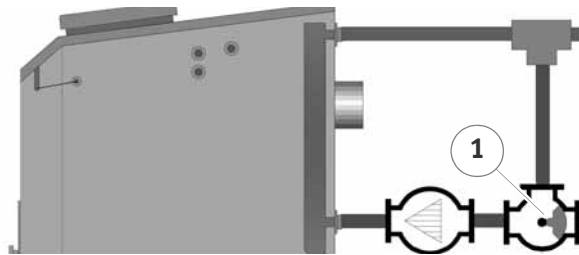

Figure 7/2 - Return valve Y1

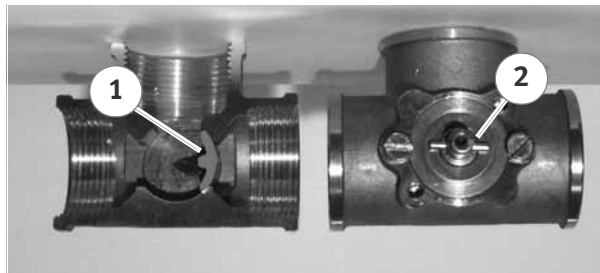

Figure 7/3 - Return valve Y1

The switch (1) of the servo motor has to be moved in the position as shown in figure 7/4.



Figure 7/4 - Switch servo motor

The closed door (1) is shown by groove (2) at the axle of the return Valve Y 1.

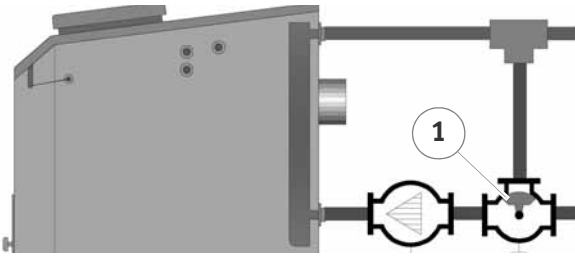

Figure 7/5 - Return valve Y1

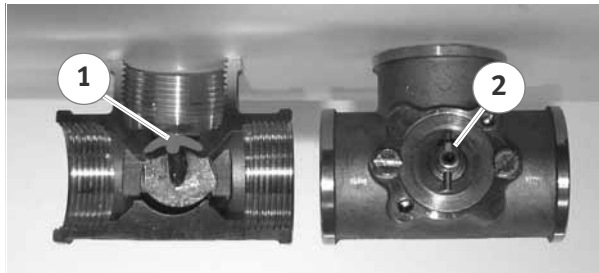

Figure 7/6 - Return valve Y1

- Fan
- Door opener (not fitted on HDG Navora 20/25/30 with HDG Lambda Control 1)
- Primary (air) actuator motor
- Secondary (air) actuator motor
- Charging valve (Y2)
- 🔗 See testing sequences „Return valve (Y 1)“ one page before.
- Change-over contact
- Illumination (display)
- Heat production on LED
- Refill LED
- Fault LED



After the last component has been tested, the display will automatically change the HDG Lambda Control 1 control system to **“Heat production off”** mode.

The HDG Navora 20/25/30 with HDG Lambda Control 1 log wood boiler does not require any additional settings.

8. Heat up the HDG Navora.

🔗 See chapter “4 Using the HDG Navora Wood Boiler”, section “4.6 Lighting and refuelling the HDG Navora”.

✓ The HDG Navora is now fully operational.

8 Notes on dismantling and disposal

8.1 Dismantling



Danger!

Material damage and injury due to incorrect disassembly.

Only dismantle the boiler after you have thoroughly read the manual.

The HDG Navora can be dismantled as follows.

1. Allow the fire in the HDG Navora to burn out and for the system to cool off.



Danger!

Danger from electrical current or voltage

The HDG Navora can only be completely de-energised by switching off the mains circuit breaker or the emergency heating switch.

2. Switch off the HDG Navora at the emergency heating switch or the mains circuit breaker.

✓ The system has been de-energised.

✓ The control is deactivated.

3. Isolate the HDG Navora from the electrical power supply.



Caution!

Danger of burns from hot surfaces and liquids.

When operating, the boiler surfaces under the cladding are hot. Even when turned off, they only cool down slowly.

Switch off the HDG Navora, and only begin dismantling it after it has cooled down.

4. Once it has cooled down, drain the heating water from the system.

5. Whilst maintaining the personal safety regulations, separate the boiler from the HDG Navora.

6. Dismantle the individual components of the HDG Navora.

✓ The combustion chamber has been dismantled.

**Caution!**

Hand injuries

Some of the combustion chamber components are very heavy and can cause injuries if they are not handled with care.

8.2 Disposal

The following components are made of steel and can be recycled via a local recycling centre.

- Boiler
- Cladding

The electrical components can also be recycled via the local recycling centre.

Fibreglass, mineral wool and plastic parts should be handed in to the relevant waste disposal centres.



Oily or greasy components and capacitors may only be disposed of through a specialist waste disposal centre.

9 Warranty and extended warranty

9.1 Specification

For the boiler body, we have extended the compulsory warranty period from two to five years.

For electrical and other components, the warranty period is two years.

9.2 Extended warranty conditions

In addition to any legal stipulations, the following legal requirements must also be met for all warranty claims:

- The HDG Navora must be commissioned by our customer service department or by an authorised specialist company.
- The HDG Navora must be operated as specified in the operating manual.
- The installation of the HDG Navora and the hydraulic components must meet the requirements in the HDG planning and installation instructions and the specified HDG hydraulic schemes.
- The HDG Navora must be installed to applicable rules, regulations and guidelines.
- The fuel quality must correspond to the requirements specified by HDG Bavaria GmbH.
- The apparent defect is to be remedied by HDG Bavaria GmbH.

9.3 Warranty exclusions

Unauthorised modifications and damage due to excessive force are not covered by the warranty.

The warranty does not cover:

- Damage due to improper use or installation, nor damage caused by inadequate maintenance or by the operation of the the system and the HDG Navora in an impermissible way.
- Damage caused by external influences (such as fire, water, lightning, excess voltage) and normal wear and tear (e.g. of seals etc).
- Corrosion damage, which is caused by operating the system below the minimum nominal thermal output level specified by the manufacturer.
- Corrosion damage, which results from the use of non-approved fuels.
- Corrosion damage, which is caused by operating the system below the specified minimum boiler return temperature.
- Damages caused by subjecting the boiler sheeting to extreme heat, as the result of blockages on the water side.

10 Declaration of conformity

EC declaration of conformity

in accordance with the EC directive machinery 98/37/EC, annex II A

as well as: 2006/ 95/ CE - L 374/10 (Voltage limits) Directive of the european Parliament and of the council of 12 December 2006 on the harmonisation of the laws of Member States relating to electrical equipment designed for use within certain voltage limits (codified version)
EG 89/ 336/EWG - L139/89 (Electromagnetic compatibility) Council directive of 3 MAY 1989 on the approximation of the laws of the member states relating to electromagnetic compatibility (89/336/EEC)

97/ 23/ EC (Pressure equipment) Directive 97/23/EC of 1997-05-29 on the approximation of the laws of the member states concerning pressure equipment

The construction of the machinery

Make: HDG Navora
Type: HDG Navora 20/25/30

has been developed, designed and manufactured in accordance with the EC directive/s as above, in the sole responsibility of

Company: HDG Bavaria GmbH, Heizsysteme für Holz
Siemensstraße 22
D-84323 Massing

The following harmonized and national standards and specifications have been applied:

EN 303-5 : 1998.11.12	Part 5: Heating boilers for solid fuels, hand and automatically stocked, nominal heat output of up to 300 kW Terminology, requirements, testing and marking
EN 1050 : 1996	Safety of machinery - Principles for risk assessment
EN ISO 12100-1 : 2003	Safety of machinery - Basic concepts, general principles for design - Part 1: Basic terminology, methodology
EN ISO 12100-2 : 2003	Safety of machinery - Basic concepts, general principles for design - Part 2: Technical principles
EN 60204-1 : 1997 12	Safety of machinery - Electrical equipment of machines - Part 1: General requirements
EN 60335-1 : 2002	Household and similar electrical appliances - Safety - Part 1: General requirements (IEC 60335-1:2001, modified)

Massing, 16.01.2008

Place, date



Signature
Wohlmannstetter
Geschäftsführer



NOTES



NOTES



NOTES

HDG Bavaria GmbH

Heizsysteme für Holz
Siemensstraße 22
D-84323 Massing
Tel. +49(0)8724/ 897-0
info@hdg-bavaria.com
www.hdg-bavaria.com