

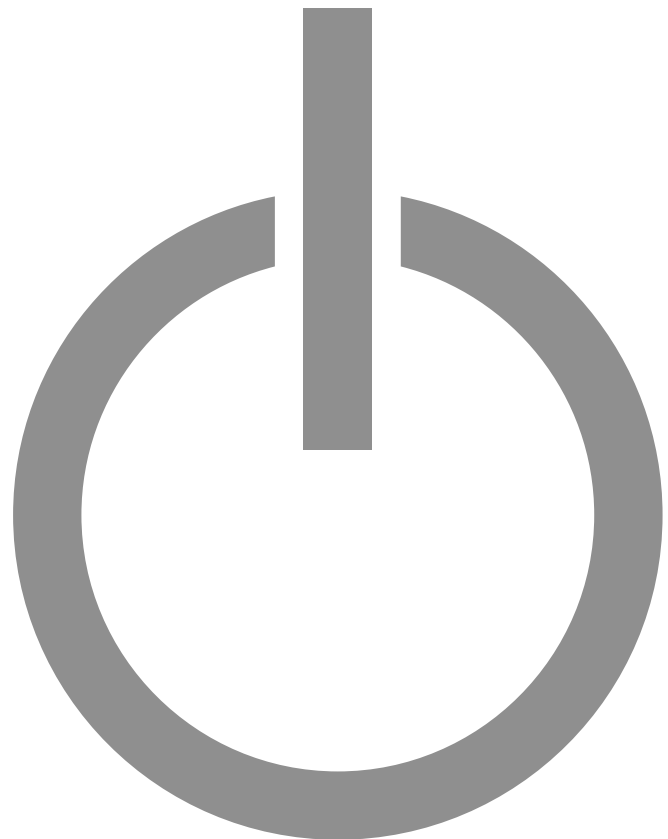

*Comfortable  
heating. With wood!*

# HDG Euro V3.0 with HDG Lambda Control 1





# Content

1	Notes on this manual .....	5
1.1	Introduction .....	5
1.2	Structure of the operating manual.....	6
1.3	Glossary .....	7
2	Safety notes .....	8
2.1	Intended use .....	8
	Useful Organisations .....	9
	Basic principles for the construction of the system.....	9
	Proper and improper manner of operation .....	9
2.2	Residual risk.....	10
2.3	Warnings and safety symbols used .....	12
2.4	Duty to inform .....	13
3	Functional description.....	14
3.1	Sectional view .....	14
3.2	Mode of operation .....	17
	HDG Euro V3.0 with HDG Lambda Control 1 .....	17
3.3	Technical data .....	18
3.4	Fuel quality requirements .....	20
	Residual moisture content .....	20
	Recommendation from HDG Bavaria GmbH .....	20
4	Using the HDG Euro.....	21
4.1	Overview of the controls and display components.....	21
	Control panel HDG Lambda Control 1 .....	21
4.2	Initialising the system .....	23
	Requirements .....	23
	Emergency heating switch .....	23
4.3	Structure of the menus .....	24
	“Heat production off” menu structure .....	24
	“Heat production on” menu structure.....	25
4.4	Displaying information .....	26
	Requirements .....	26
	How to display information .....	26
4.5	User changeable settings .....	29
	Requirements .....	29
	Setting the boiler temperature.....	29
4.6	Lighting and reloading the HDG Euro.....	30
	How to proceed .....	30
4.7	Switching off the HDG Euro for maintenance or repair work.....	38

5	Cleaning and maintaining the HDG Euro .....	39
5.1	Cleaning and maintenance plan.....	39
5.2	How to proceed .....	40
	Cleaning tools .....	41
	Cleaning the flat grate and ash compartment .....	41
	Inspecting and cleaning downstream heating surfaces and combustion chamber .....	44
	Inspecting and cleaning the flue pipe.....	46
	Inspecting and cleaning the lambda sensor .....	48
	Inspecting and cleaning the flue gas sensor .....	49
	Inspecting and cleaning the flue fan.....	50
	Inspecting and cleaning the fan unit.....	51
	Inspecting the integrity of the door seals.....	52
	Cleaning the control unit .....	55
	Calibrating the lambda sensor .....	56
	Cleaning the primary air inlets .....	57
	Cleaning the burner nozzle .....	58
	Inspecting the pneumatic springs.....	59
6	Troubleshooting .....	61
6.1	How to proceed .....	61
6.2	Possible faults .....	62
	Faults which do not interrupt the production of heat .....	62
	Faults which interrupt the production of heat .....	63
7	Commissioning the HDG Euro .....	64
7.1	Conditions .....	64
7.2	Commissioning the HDG Euro .....	65
	Switching HDG Euro on .....	65
	Configuring the control .....	65
	Setting the target boiler temperature.....	68
	Customer data .....	69
	Memorandum for set values .....	69
	Testing system components .....	70
	Setting the primary air guide and the grate height for the respective fuel ..	73
8	Notes on dismantling and disposal .....	75
8.1	Dismantling .....	75
8.2	Disposal .....	76
9	Warranty and extended warranty .....	77
9.1	Specification .....	77
9.2	Extended warranty conditions .....	77
9.3	Warranty exclusions .....	78
10	Declaration of conformity .....	79

# 1 Notes on this manual

## 1.1 Introduction

### SAFE AND SIMPLE OPERATION

This Operation Manual contains important information for proper and safe operation of the HDG Euro V3.0 with HDG Lambda Control 1. Following these instructions serves in avoiding dangers, preventing repair costs and downtimes, maintaining reliability and extending the service life of the heating system.

### READING THE OPERATION MANUAL

This Operation Manual must be read and applied by everyone who operates or works on the HDG Euro V3.0 with HDG Lambda Control 1.

### TECHNICAL CHANGES

We continuously develop and improve our boilers. The information in this version was correct at the time of going to press.

We reserve the right to make changes which may then deviate from the technical details and illustrations in this Operation Manual.

### COPYRIGHT

Written agreement is required from HDG Bavaria GmbH for any reprints, storage in a data-processing system or transmission by electronic, mechanical, photographic or any other means, and for copies or translations of this publication, in whole or in part.

### SYMBOLS USED

In this Operation Manual the following denotations or symbols will be used for particularly important information:

1. Instructions to the operator
  2. Work through the steps in the sequence specified.
- ✓ Result of the action described
  -  Cross reference for more explanation
  - List
    - List

## 1.2 Structure of the operating manual

The operating manual is structured as follows:

Chapter	This explains ...
1 Notes on this manual	... how to use this operating manual.
2 Safety notes	... everything on the subject of safety that you should consider when using the heating system.
3 Functional description	... the structure and all of the features of the heating system
4 Using the HDG Euro	... how to properly operate the HDG Euro.
5 Cleaning and maintaining the HDG Euro	... how to clean the HDG Navora and who is responsible for its maintenance.
6 Troubleshooting	... how to rectify faults in the heating system.
7 Commissioning the HDG Euro	... how the HDG Euro is to be put into initial service.
8 Notes on dismantling and disposal	... what has to be considered when dismantling and disposing of the HDG Euro.
9 Warranty	... what the terms and conditions of the warranty are.
10 Appendix	... the EC Declaration of Conformity.

Table 1/1 - Structure of the operating manual

## 1.3 Glossary

Term	Explanation
Actuator	This is a component which carries out a certain function in the heating system, e.g. the thermal safety device (TAS).
Display	Display on HDG Lambda Control 1 control panel.
Flue fan	Creates a vacuum inside the boiler and provides the boiler with air for combustion.
HDG Euro V3.0 with HDG Lambda Control 1	Boiler for burning split logs.
HDG Lambda Control 1	Microprocessor controller to regulate combustion and the heating of the buffer tank.
Lambda sensor	Electrical component which monitors residual oxygen levels in the flue gas.
Plug board	Pre-fabricated connection strip for electrical components
Refill button	Button that must be pressed before the boiler is opened for refilling, or lighting a fire.
Refill signal	Electrical signal (in the form of an LED on the Lambda Control panel) which serves as a prompt to refill the fuelling chamber.
Sensor	Monitors certain parameters (e.g. temperature) and forwards them to the control system for analysis.
Thermal safety device	Safety device which allows cold water to flow through the safety heat exchanger if the boiler becomes too hot.

Table 1/2 - Glossary

# 2 Safety notes

## 2.1 Intended use

Please note that it is a legal requirement under England and Wales Building Regulations that the installation of the appliance is either carried out under Local Authority Building Control approval or is installed by a Competent Person registered with a Government approved Competent Persons Scheme. HETAS Ltd operate such a Scheme and a listing of their Registered Competent Persons can be found on their website at [www.hetas.co.uk](http://www.hetas.co.uk).

### **IMPORTANT**

The installation of this appliance must comply with all local regulations, including those referring to national and European Standards before it can be operated.

This appliance is not suitable for a shared flue.

Improper adjustment, alteration, maintenance or the fitting of replacement parts not recommended by the manufacturer can cause injury or property damage. Do not operate the appliance with faulty seals or components.

Ensure all manuals are kept safely and are available for the user at all times.

Do not store or use petrol or other flammable vapours and liquids in the vicinity of this or any other heating appliance. Do not burn anything but natural wood.

Due to high operating temperatures of this appliance it should be located away from pedestrian traffic. Advise all persons as to the appliances high surface temperatures, including visitors. If it is possible for children or infirm adults to come into contact, fit a suitable guard. Never let children “help” with the appliance in any way, even when cold.

It is imperative that all air passageways into, out of, and within the appliance are kept clean. All permanent ventilation into the room provided must remain clear and unobstructed at all times. Consideration must be given to the need for extra ventilation if another heating source needing air is to be operated simultaneously. If an extraction fan is proposed to be fitted to a connecting area of the house, after the stove has been installed, professional advice should be sought from a qualified engineer.

If a flue blockage or adverse weather conditions cause the appliance to emit smoke, do not treat it as merely a nuisance, this smoke will indicate that carbon monoxide is being emitted into the room.

In the event of a chimney fire the appliance should be turned to its minimum setting and the fire brigade informed. Do not re-light until the complete installation has been inspected by a qualified engineer.

The appliance should be inspected regularly and the chimney cleaned at least annually. More frequent cleaning may be required and the advice of a qualified chimney sweep should be sought. Always check for any flue blockage before lighting the stove after a prolonged shut down.

This appliance has been carefully designed and constructed to give clean burning with optimum efficiency and safety, but as with all appliances these standards will not be achieved unless it is installed and maintained regularly by qualified engineers. It must also be operated strictly with the procedures given in this manual.

If you are unsure about anything concerning your appliance please seek professional advice.

### USEFUL ORGANISATIONS

Name	Phone	Web
Solid Fuel Association	0845 601 4406	www.solidfuel.co.uk
The National Association of Chimney Sweeps	01785 811732	www.chimneyworks.co.uk
HETAS Ltd.	0845 634 5626	www.hetas.co.uk

Table 2/1 - Useful Organisations

### BASIC PRINCIPLES FOR THE CONSTRUCTION OF THE SYSTEM

#### BASIC PRINCIPLES

The heating system was built using state of the art technology and conforms to recognised safety regulations. Nevertheless, its use still incurs the risk of injury or death of the user or a third party or of adverse effects upon the heating system itself or upon other material goods. **Have your specialist heating company provide you with detailed instruction on the operation of the heating system.**

#### USING THE HEATING SYSTEM

Only use the heating system if in perfect condition. Use it properly, as intended, and be aware of safety concerns and the dangers involved under observance of the Operation Manual. Have any faults which could impair safety immediately fixed.

### PROPER AND IMPROPER MANNER OF OPERATION

#### APPLICATION OF THE HEATING SYSTEM

The HDG Euro V3.0 with HDG Lambda Control 1 is designed to burn untreated wood in the form of split logs up to 500 mm (19"), pressed briquettes and coarse wood chips, coarse grade, cross section of maximum 1000 mm<sup>2</sup> and not less than 600 mm<sup>2</sup>). Varnished, coated or impregnated wood should never be used for fuel.

Any other application is considered improper use. The manufacturer will accept no liability for any damage resulting from improper use. The operating company bears sole responsibility in such cases.

UK SMOKE CONTROL  
AREAS

Proper use includes adherence to the installation, operation and maintenance requirements specified by the manufacturer.

Modification of the specified operating values will affect the heating system's control program and could lead to malfunctions. Only trained maintenance and operating personnel may undertake modifications to the operating values.

The use of materials with other technical burning characteristics requires comprehensive modification of the control parameters by qualified specialists.

The Euro 30, 40 and 50 models have been recommended for exemption under Section 21 of the Clean Air Act 1993 for use in smoke control areas when burning wood logs which are selected in accordance with the recommendations on fuel in this manual, see section “3.4 Fuel quality requirements” in chapter “3 Functional description”.

## 2.2 Residual risk

Despite all precautions, the following residual risks remain:



### Caution!

Hot surface.

Contact with the hot surfaces of the boiler can lead to burns.

Wait until the boiler has cooled down before touching uninsulated components.



### Warning!

Danger of asphyxiation due to carbon monoxide.

If the boiler is operating, carbon monoxide can be emitted through the open doors.

Do not leave the doors open any longer than necessary.



### Caution!

Danger of fire

Working in areas marked with this symbol can lead to a fire.

Do not leave the combustion chamber and/or fuelling chamber door open any longer than necessary.



### Caution!

Hand injuries

Working in areas marked with this symbol can lead to hand injuries.



**Danger!**

Danger from electrical current or voltage.

Work in areas marked with this symbol may only be done by a qualified electrician.

---



**Danger!**

Danger of explosion.

Work in areas marked with this symbol may only be performed exactly as specified by HDG Bavaria.

Improper operation can lead to explosions.

---

## 2.3 Warnings and safety symbols used

The following warnings and safety symbols are used in this Operation Manual:



**Danger!**

Danger from electrical current or voltage.

Work in areas marked with this symbol may only be done by a qualified electrician.



**Warning!**

Warning of a hazardous area.

Working in areas marked with this symbol can lead to serious injuries or to extensive material damage.



**Caution!**

Hand injuries

Working in areas marked with this symbol can lead to hand injuries.



**Caution!**

Hot surface

Working in areas marked with this symbol can lead to burns.



**Caution!**

Danger of fire

Working in areas marked with this symbol can lead to a fire.



**Caution!**

Frost danger

Working in areas marked with this symbol can lead to frost damage.

**Danger!**

Danger of explosion.

Work in areas marked with this symbol may only be performed exactly as specified by HDG Bavaria.

Improper operation can lead to explosions.

**Caution!**

Danger from suspended loads.

Working in areas with this symbol may involve danger from falling objects.



Notes on disposal.



Additional information for the operator.

## 2.4 Duty to inform

### READING THE OPERATION MANUAL

Every person performing any tasks on the system is required to read the Operation Manual prior to beginning work, particularly the chapter “2 Safety notes”.

This holds especially true for persons who only occasionally work on the heating system, e.g. when cleaning or servicing it.

The Operation Manual must be kept easily accessible at the heating system's installation location.

# 3 Functional description

## 3.1 Sectional view

The boiler contains the following components:

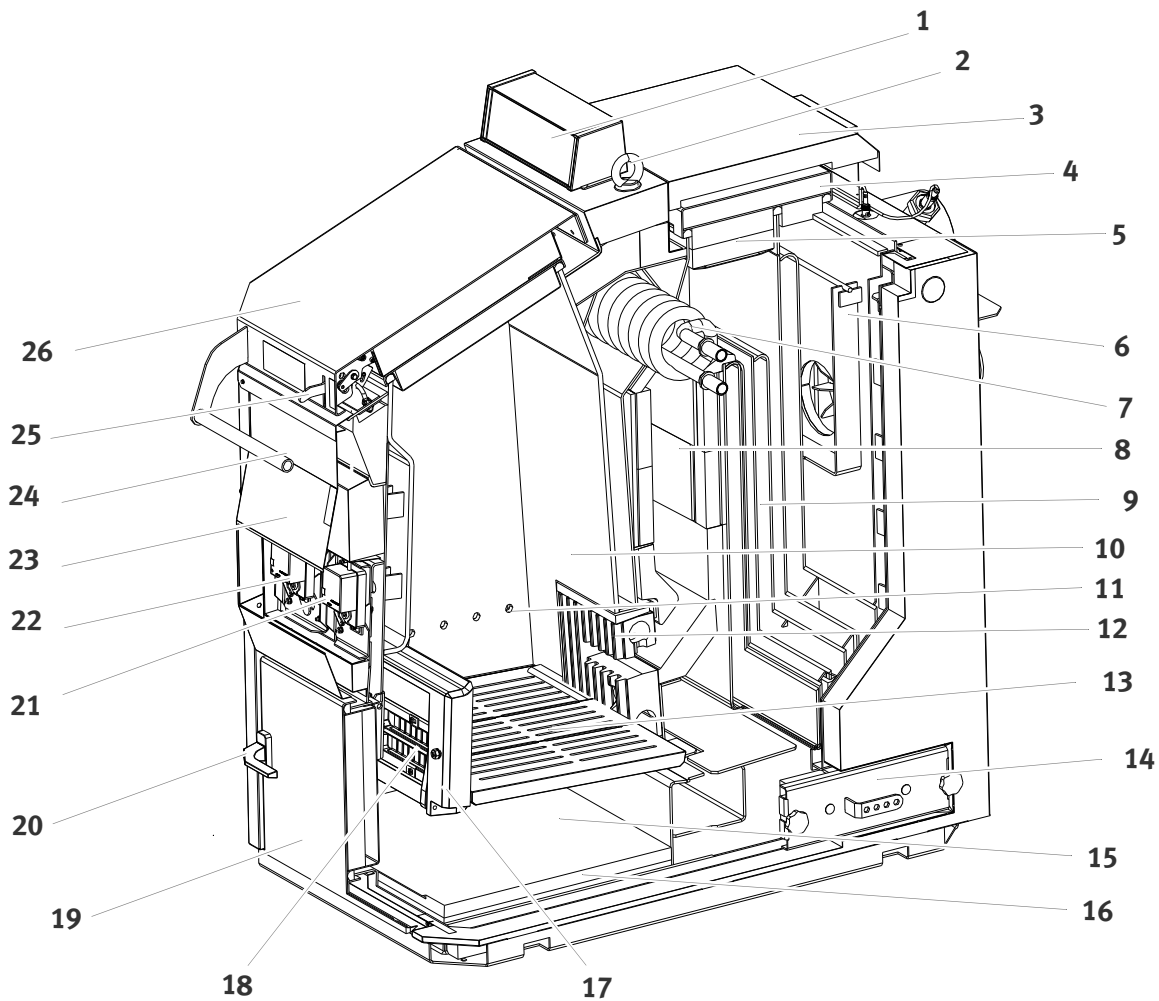

Figure 3/1 - Overview

- 1 HDG Lambda Control 1 control unit
- 2 Eyebolt for crane transport
- 3 Cleaning lid cover
- 4 Cleaning lid
- 5 Cleaning lid with heat shield
- 6 Flue gas deflector plate
- 7 Safety heat exchanger
- 8 Secondary combustion chamber with chamber stones
- 9 Flue gas heat exchanger (downstream heating surfaces)



- 10 Fuel chamber
- 11 Primary air inlet
- 12 Burner nozzle
- 13 Grate
- 14 Cleaning opening of fly ash compartment
- 15 Ash compartment
- 16 Ash compartment cladding
- 17 Fixed grate portal
- 18 Cleaning flap
- 19 Cleaning door
- 20 Cleaning door handle
- 21 Air adjustment flap for primary air with servo motor
- 22 Air adjustment flap for secondary air with servo motor
- 23 Front cover
- 24 Filling hatch handle
- 25 Filling hatch unlocking device
- 26 Filling hatch

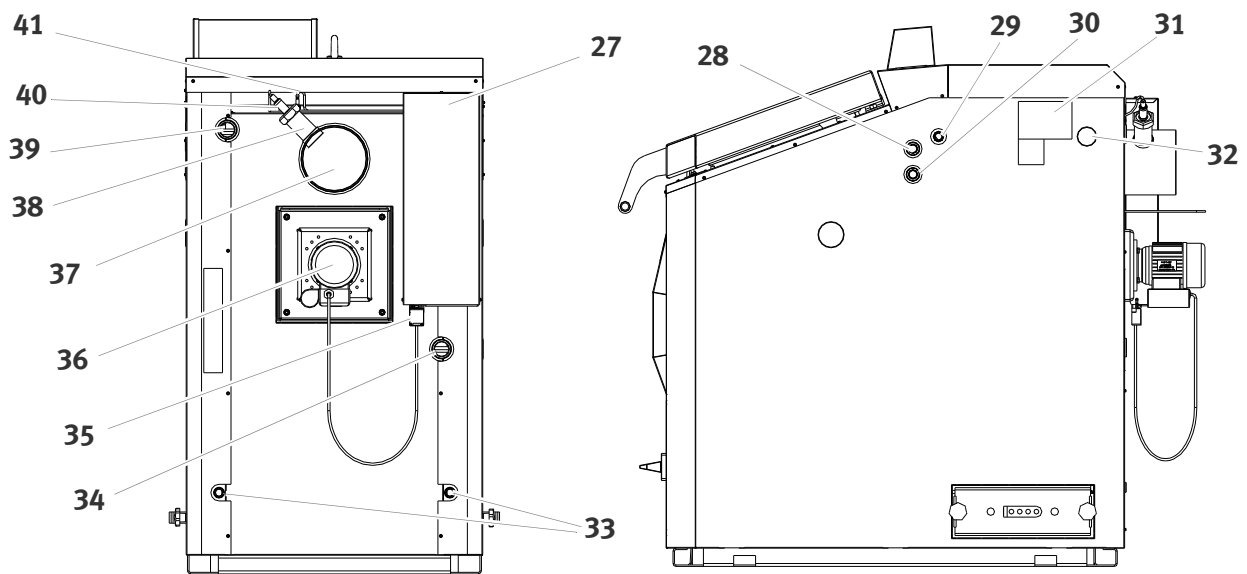

Figure 3/2 - Overview

- 27 Circuit board for HDG Lambda Control 1
- 28 Safety heat exchanger inlet 1/2" BSP (DN 15 IG)
- 29 Connection for immersion bushing on thermal safety device 1/2" BSP (DN 15 IG)
- 30 Safety heat exchanger outlet 1/2" BSP (DN 15 IG)
- 31 Nameplate
- 32 Cover cap of safety temperature limiter sensor
- 33 Filling/draining 1/2" BSP (DN 15 IG)
- 34 Return connection 1 1/4" BSP (DN 32 IG)
- 35 Plug for flue fan
- 36 Flue fan
- 37 Flue connection
- 38 Lambda sensor connection nozzle
- 39 Supply connection 1 1/4" BSP (DN 32 IG)
- 40 Lambda sensor
- 41 Flue gas temperature sensor

## 3.2 Mode of operation

### HDG EURO V3.0 WITH HDG LAMBDA CONTROL 1

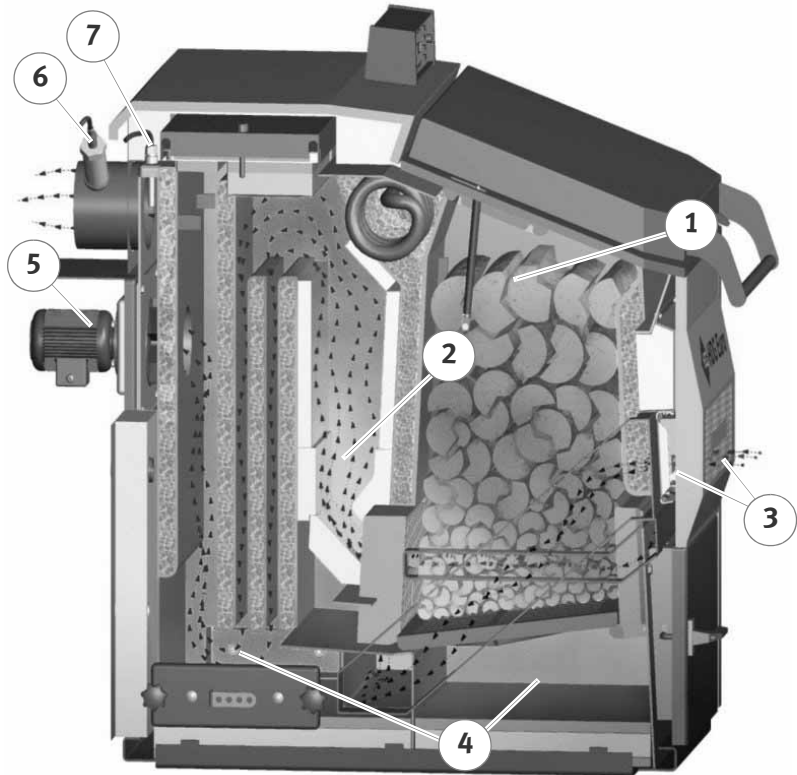

Figure 3/3 - HDG Euro V3.0 with HDG Lambda Control 1

Inside the HDG Euro V3.0 with HDG Lambda Control 1, fuel which has been manually placed in the fuel chamber (1) and ignited is degassed through the addition of primary air.

The resulting wood gas is mixed with secondary air in the combustion chamber (2) where it is burnt off.

Ashes are collected in the large ash compartments (4) for combustion ash and fly ash.

The air necessary for combustion is supplied as required via the suction fan (5) and two servo drives with metering mechanisms (3).

Via the lambda sensor (6), the boiler temperature sensor and the flue gas temperature sensor (7):

- the firing is permanently monitored,
- the boiler output is adjusted,
- emissions are minimised and
- boiler efficiency is optimised.

HDG LAMBDA CONTROL 1

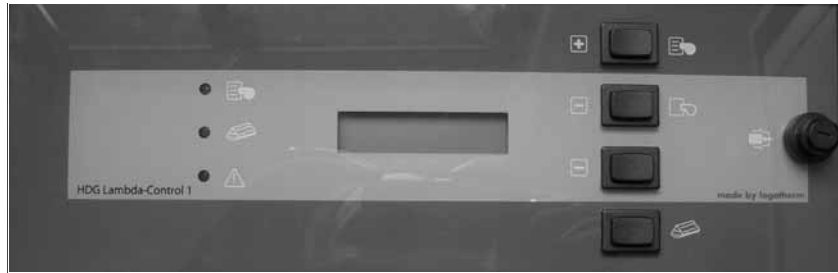

Figure 3/4 - Control panel for HDG Lambda Control 1

The HDG Lambda Control 1 boiler control unit is the electronic hub. Using the control panel, you can regulate the HDG Lambda Control 1 system and call up information on the current operating status.

See section “4.3 Structure of the menus” in chapter “4 Using the HDG Euro”.

### 3.3 Technical data

Type of boiler	HDG Euro V3.0	HDG Euro V3.0	HDG Euro V3.0
Minimum power	29 kW	29 kW	29 kW
Nominal power for wood	30 kW	40 kW	50 kW
Boiler class	3	3	3
Weight	979 kg	979 kg	979 kg
Max. operating pressure	3 bar	3 bar	3 bar
Max. supply temperature	95 °C	95 °C	95 °C
Water content	178 l	178 l	178 l
Flue draught requirement	20 Pa	20 Pa	20 Pa
Exhaust mass flow			
• Nominal load	0.0180 kg/s	0.0240 kg/s	0.0303 kg/s
• Partial load	0.0172 kg/s	0.0172 kg/s	0.0172 kg/s
Exhaust temperature (approx.)			
• Nominal output	140 °C	160 °C	180 °C
• Minimum output	120 °C	120 °C	120 °C
Fuelling chamber capacity	220 l	220 l	220 l
Burning duration per filling, in accordance with fuel recommendations	Up to 7 h with beech, up to 6 h with spruce	Up to 6 h with beech, up to 5 h with spruce	Up to 5 h with beech, up to 4 h with spruce

Table 3/1 - Technical data HDG Euro V3.0 with HDG Lambda Control 1

Type of boiler	HDG Euro V3.0	HDG Euro V3.0	HDG Euro V3.0
Boiler efficiency	90,6 %	90,3 %	89,9 %
Electrical connection <ul style="list-style-type: none"> <li>Voltage</li> <li>Current consumption</li> <li>Continuous operation</li> </ul>	230 V 0.76 A	230 V 0.76 A	230 V 0.76 A
Required auxiliary energy <ul style="list-style-type: none"> <li>Constant operation at nominal power</li> </ul>	175 W	175 W	175 W
Diameter of flue outlet	180 mm external	180 mm external	180 mm external
Height of flue connection	1106 mm	1106 mm	1106 mm
Safety heat exchanger connections (bushing)	2 x 3/4" BSP (DN 20)	2 x 3/4" BSP (DN 20)	2 x 3/4" BSP (DN 20)
Flow and return connections (bushing)	1 1/4" BSP (DN 32)	1 1/4" BSP (DN 32)	1 1/4" BSP (DN 32)
Drain (bushing)	2 x 1/2" BSP (DN 15)	2 x 1/2" BSP (DN 15)	2 x 1/2" BSP (DN 15)
Water-side resistance at $\Delta\theta$ 10 K	24 hPa	24 hPa	24 hPa
Water-side resistance at $\Delta\theta$ 20 K	6.4 hPa	6.4 hPa	6.4 hPa
Air inlet cross section	15.000 mm <sup>2</sup>	15.000 mm <sup>2</sup>	15.000 mm <sup>2</sup>

Table 3/1 - Technical data HDG Euro V3.0 with HDG Lambda Control 1

## 3.4 Fuel quality requirements

### RESIDUAL MOISTURE CONTENT

When selecting fuel, it is important to understand that the thermal value of the wood is primarily dependent upon the moisture content. For the purpose of simplifying cost calculations, you can assume that 1 kg of wood (all types) with a moisture content of 20 % has a thermal value of approx. 4 kWh. Firewood must be split and its size must be adapted accordingly to fit in the fuelling chamber.

Unsplit logs and square boards are not suitable for burning.

Moreover, logs should be split before they are prepared for drying. This is done in order to achieve a moisture content which is suitable for burning within a reasonable amount of time (approx. two years).

Moist, unsplit wood has a negative impact on the combustion efficiency of the boiler and results in higher fuel consumption.

### RECOMMENDATION FROM HDG BAVARIA GMBH

HDG Bavaria recommends split logs in lengths of 500 mm (19"), with a max. edge length of 120 mm (4 3/4") and a moisture content of 20 %.

# 4 Using the HDG Euro

## 4.1 Overview of the controls and display components

### CONTROL PANEL HDG LAMBDA CONTROL 1

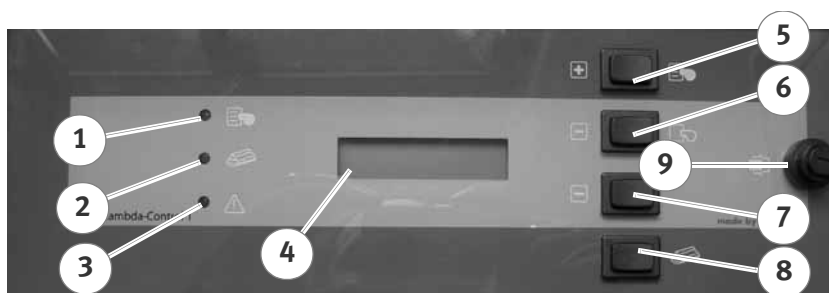



Figure 4/1 - Control panel for HDG Lambda Control 1

- 1 “Heat production on” indicator
- 2 “Reload” indicator
- 3 “Fault” indicator
- 4 Text display
- 5 “Heat production on/plus” button
- 6 “Heat production off/minus” button
- 7 “Arrow” button
- 8 “Reload” button
- 9 Unlocking knob for the safety temperature limiter (STB)

The HDG Lambda Control 1 control panel is located on the top of the HDG Euro V3.0 with HDG Lambda Control 1.

Using the control panel, you can regulate the HDG Lambda Control 1 system and call up information on the current operating status.

The display shows the selected information and settings. In the operating mode “Heat production on”, the display is switched on and active. In the operating mode “Heat production off”, the display switches off after 15 minutes. It can be switched on again by pressing any button.

 In section “4.3 Structure of the menus” in this chapter, all selectable information and parameters are listed.

#### DISPLAY

#### “HEAT PRODUCTION ON” INDICATOR



The “**Heat production on**” indicator (1) lights up when the combustion process is started by pressing the “*Heat production on*” button (5), or when the process starts automatically (if the flue gas

“RELOAD” INDICATOR



temperature is sufficient). The indicator goes dark when the combustion process is stopped via the “*Heat production off*” button, or when the process is automatically stopped due to lack of fuel.

The “**Reload**” indicator (2) lights up when heat production has been switched off or when system heating requirements necessitate reloading. The indicator flashes during the reloading and goes dark when heat production is switched on.

See section “4.6 Lighting and reloading the HDG Euro” in this chapter.

“FAULT” INDICATOR



The “**Fault**” indicator (3) lights up when faults occur which prevent the further production of heat or which prevent heat production from being switched on. The indicator flashes when faults occur which allow heat production to continue or which enable heat production to be switched on (e.g. control set to an alternative program until the fault is eliminated). It goes dark once faults have been resolved and acknowledged.

KEYPAD

The HDG Euro can be operated using the keypad. The individual buttons have the following functions:



“*Heat production on/plus*” button

- In menu level 1, the system is switched to “Heat production on” operating mode
- In the submenu, parameters can be selected and their respective settings can be changed.



• “*Heat production off/minus*” button

- In menu level 1, the system is switched into “Heat production off” operating mode, or the reloading function is prematurely stopped.
- In menu level 2, parameters can be selected and their respective settings can be changed.



“*Arrow*” button

- Access to the selection menu.
- Confirms the function selected with the “Plus” or “Minus” buttons.

Confirms changes to settings.



“*Reload*” button

- The flue fan is activated when the button is pressed. Instructions on how to proceed with opening the filling hatch will appear in the display of the HDG Lambda Control 1.

See section “4.6 Lighting and reloading the HDG Euro” in this chapter.



- Unlocking knob for the safety temperature limiter (*STB*). If the *STB* is triggered as a result of the boiler temperature being too high, the *STB* has to be reset by pressing the reset knob after the boiler temperature has dropped to approx. 80°C. The fault is automatically reset.

## 4.2 Initialising the system

### REQUIREMENTS



In order for the HDG Euro to be switched on, it must first have been put into service by an authorised specialist.

 See chapter “7 Commissioning the HDG Euro”.

### EMERGENCY HEATING SWITCH

The system is connected to the mains supply through an emergency heating switch (provided by the customer) or through a circuit breaker in the mains distribution box of the home.



#### **Danger!**

Danger from electrical current or voltage.

The HDG Euro can only be completely de-energised by switching off the mains circuit breaker or the emergency heating switch.

1. Switch on the HDG Euro at the corresponding circuit breaker or the emergency heating switch provided by the customer.
- ✓ The HDG Euro ready is for operation.

## 4.3 Structure of the menus

### “HEAT PRODUCTION OFF” MENU STRUCTURE

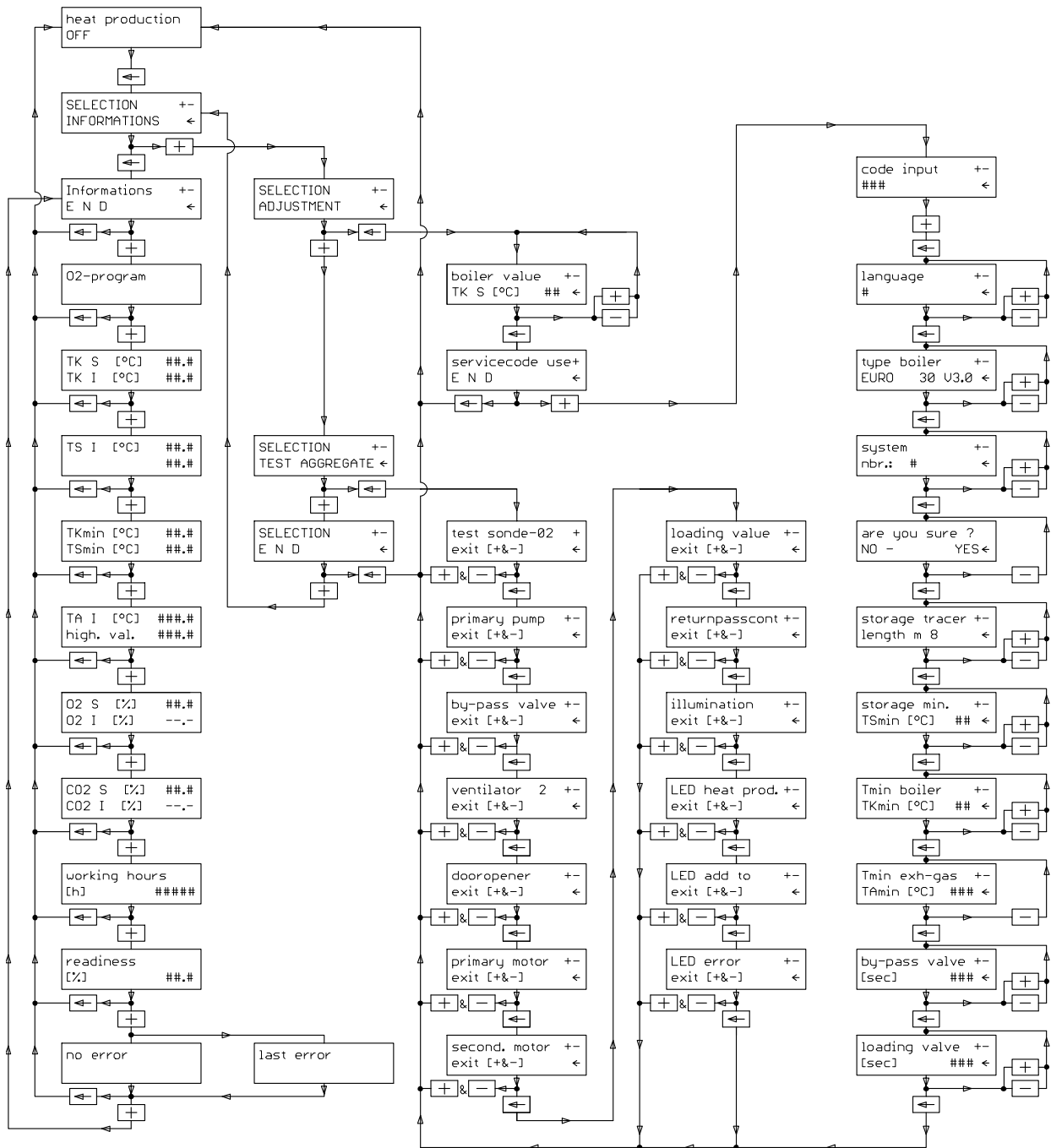

Figure 4/2 - “Heat production off” menu structure

### “HEAT PRODUCTION ON” MENU STRUCTURE

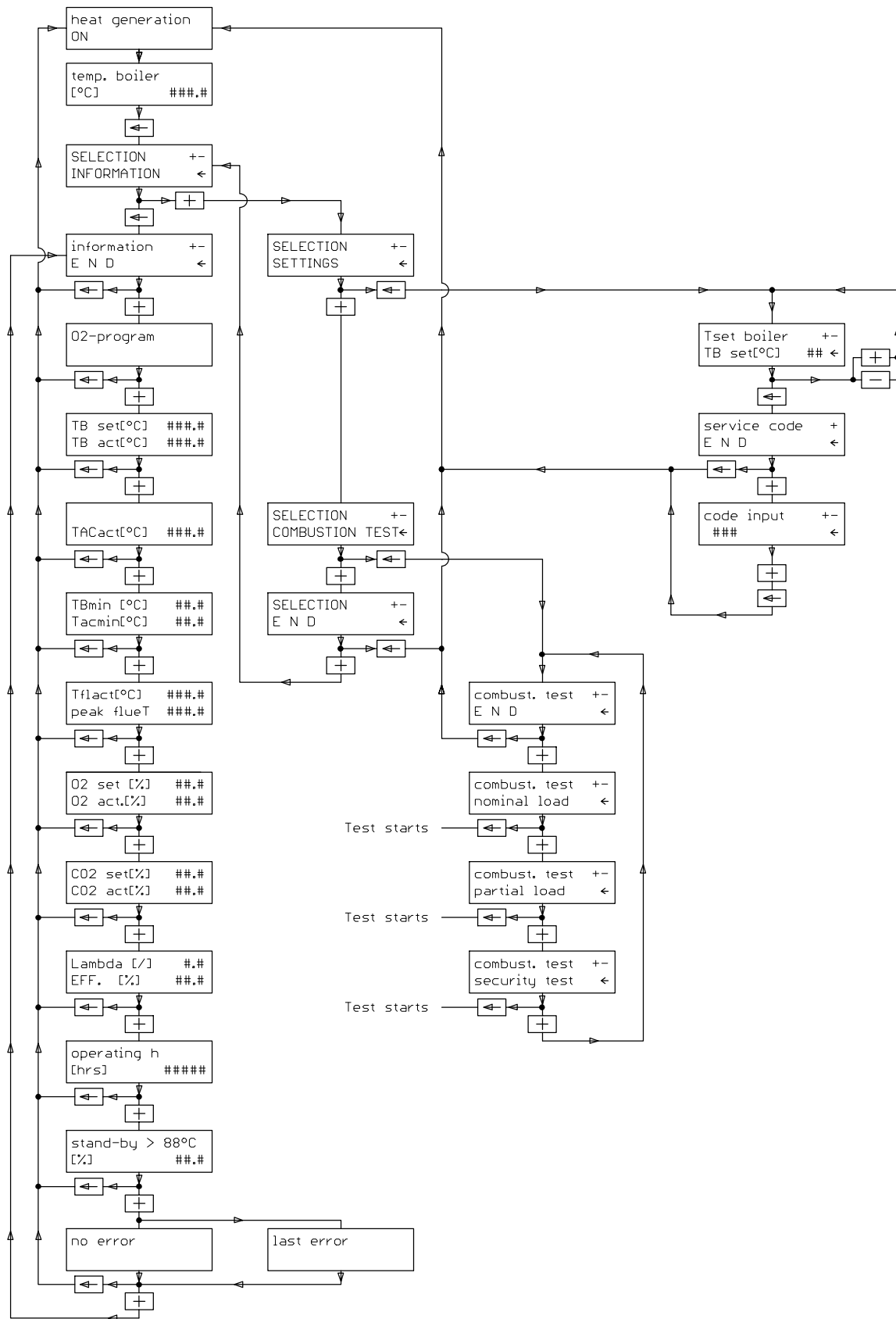

Figure 4/3 - “Heat production on” menu structure

## 4.4 Displaying information

You can call up a variety of information on the display of the HDG Lambda Control 1.



Certain information and settings can only be accessed and changed in “Heat production on” or “Heat production off”.

See section “4 Using the HDG Euro” in chapter “4.3 Structure of the menus”.

### REQUIREMENTS

Before the HDG Euro can be switched on and information and settings can be accessed and changed, the following requirements must be met.

- The HDG Euro has been commissioned by authorised specialists.
- The fuse on the power supply is switched on.

### HOW TO DISPLAY INFORMATION



The buttons on the control panel of the HDG Lambda Control must be pressed and held for approx. two seconds in order to jump to another menu item.

If a button is not pressed after 30 seconds, the selection menu will be abandoned automatically.

See chapter “4 Using the HDG Euro”, section “4.1 Overview of the controls and display components”.

SELECTION MENU IN “HEAT  
PRODUCTION OFF” MODE

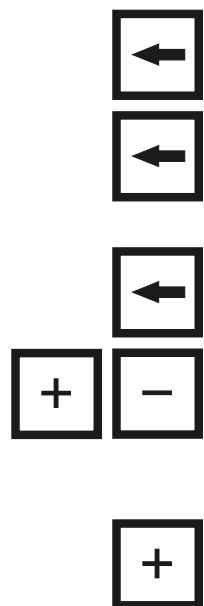
- 
1. Press the *Arrow* button.  
✓ The display is activated.
  2. Press the *Arrow* button.  
✓ The selection menu **Selection**, submenu **Information**, appears in the display.
  3. Press the *Arrow* button.  
✓ **Information** and **End** will appear in the display.
  4. Press the *Plus* button to scroll forward through the information or *Minus* to scroll backwards through the information.  
✓ The **O2 Control program** information is displayed by pressing the Plus button.
  5. Continue pressing the *Plus* button until you have obtained all of the desired information.

## ACCESSIBLE INFORMATION

Preset target values, current actual values and analyses:

Display	Description		Authorised	
TK S	[°C]	82.0	• Maximum required boiler water temperature.	Operator
TK I	[°C]	73.4	• Current actual value.	
TS I	[°C]	23.8	• Current accumulator temperature.	No access
TK min	[°C]	60.0	• Required minimum boiler temperature.	Operator
TS min	[°C]	45.0	• Required minimum accumulator temperature.	Operator
TA I	[°C]	23.0	• Current flue gas temperature.	
<b>Peak value</b>		226.0	• Highest reached flue gas temperature.	No access
O2 S	[%]	6.0	• Preset target value for residual oxygen	Manufacturer
O2 I	[%]	5.6	• Current actual value for residual oxygen	
CO2 S	[%]	15.4	• Target value for carbon dioxide	No access
CO2 I	[%]	15.8	• Calculated actual value for carbon dioxide.	
<b>Lambda</b>	[/]	1.9	• Current excess air coefficient	
<b>ETA-F</b>	[%]	100.0	• Current degree of combustion efficiency	No access
<b>Operating hours</b> [h]			• Cumulative operating hours in “ <b>Heat production on</b> ” mode.	No access

Table 4/1 - Target value information

Display	Description	Authorised
<b>Operational readiness</b> [%]                      0.0	<ul style="list-style-type: none"> <li>• Display of the percentage of operating hours during which the boiler temperature was above 88 °C (*) during the last 500 hours.</li> </ul>	No access
<b>Last fault</b>	<ul style="list-style-type: none"> <li>• Most recent fault since the last query.</li> </ul>	Operator

Table 4/1 - Target value information



(\*) If this value is too high, there is a danger of excessive soiling of the boiler and the chimney!

**Danger of fire in the chimney and flue!**

See the following example calculation.

EXAMPLE CALCULATION FOR OPERATIONAL READINESS

**450 operating hours at 20% readiness equates to 90 hours with the boiler temperature above 88 °C.**

Consequence: The boiler would thus have been **overheated** for 90 hours.

CONTROL PROGRAM:

Control program	Indication in display	Description
Standard control program	O <sub>2</sub> control program	<ul style="list-style-type: none"> <li>• Combustion is regulated according to the residual oxygen content as measured by the O<sub>2</sub> sensor</li> </ul>
Alternative control program	TA control program	<ul style="list-style-type: none"> <li>• If the O<sub>2</sub> sensor malfunctions or is defective, the HDG Lambda Control microprocessor controller switches from the standard control program to the alternative control program and uses the flue gas temperature to regulate combustion, thus ensuring temporary emergency operation</li> </ul>

Table 4/2 - Control program information



Indication in display when the alternative “**TA control program**” is automatically initiated.

## 4.5 User changeable settings

### REQUIREMENTS

In order to be able to proceed with making changes and corrections to the settings, the following requirements must be met.

- The HDG Euro has been commissioned by authorised specialists.
- The fuse on the power supply is switched on.

### SETTING THE BOILER TEMPERATURE.

SELECTION MENU IN “HEAT  
PRODUCTION OFF” MODE

The display reads **Heat production off.**



1. Press the *Arrow* button.

✓ The selection menu **Selection** submenu **Information** will appear in the display.



2. Press the *Plus* button.

✓ The display changes to the **Settings** submenu.



3. Press the *Arrow* button.

✓ The menu item is confirmed; **Boiler target value TK S [°C]** appears in the display.



4. Use the *Plus* button to increase the value, or the *Minus* button to reduce the value.



Please note!

Adjustable range **80 °C to 84 °C**. **HDG recommendation: 82 °C.**

✓ The desired value is set.



5. Press the *Arrow* button.

✓ The target boiler temperature is assumed.



6. Press the *Arrow* button.

✓ The submenu closes and **Heat production off** appears in the display again.

✓ The boiler target temperature is set.

✎ See section “4.3 Structure of the menus” in this chapter for more information.

## 4.6 Lighting and reloading the HDG Euro

HEATING UP WHEN THE  
SYSTEM IS COLD

### HOW TO PROCEED

Despite all precautions, the following residual risks remain:



#### Caution!

Hot surface.

Contact with the hot surfaces of the boiler can lead to burns.

Wait until the boiler has cooled down before touching uninsulated components.



#### Danger!

Danger of asphyxiation due to carbon monoxide.

If the boiler is operating, carbon monoxide can be emitted through the open filling hatch.

Do not leave the combustion chamber and/or filling hatch open any longer than necessary.



#### Warning!

Danger of fire

Working in areas marked with this symbol can lead to a fire.

Do not leave the filling hatch open any longer than necessary.



#### Danger!

Danger of explosion.

Work in areas marked with this symbol may only be performed exactly as specified by HDG Bavaria.

Improper operation can lead to explosions.



#### Caution!

Hand injuries

Working in areas marked with this symbol can lead to hand injuries.

## OPERATING STATUS

When the “Reload” indicator lights up, there are no more embers in the fuel chamber.

 See also section “4.1 Overview of the controls and display components”, paragraph “Control panel HDG Lambda Control 1” in this chapter.



1. Press the *Reload* button.
  - ✓ The message “**Do not open, please wait**” appears in the display of the HDG Lambda Control system.
  - ✓ The flue fan starts to run.
  - ✓ After approx. 15 seconds, the message “**Unlock filling hatch**” appears.
2. Press the lock (2) of the filling hatch (1) downward.

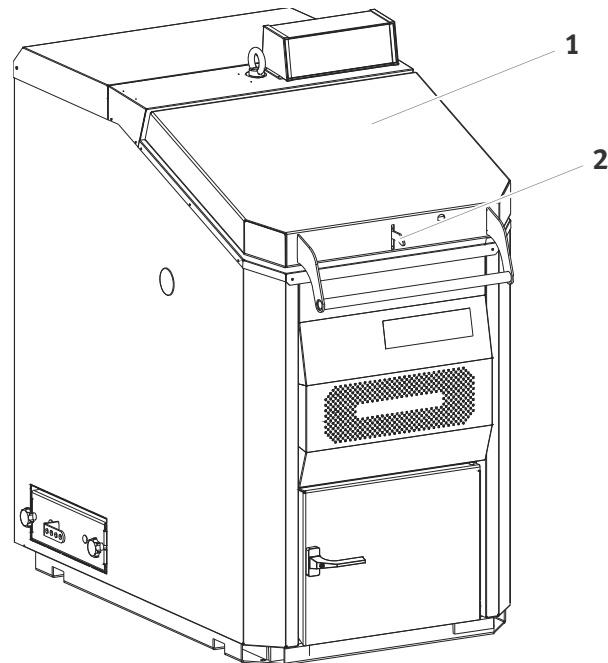

Figure 4/4 - Heating up / reloading

3. Raise the filling hatch (1) up to the stop.
4. Wait for approx. 10 seconds until the message “**Careful, open slowly**” appears.

5. Lift the lock of the filling hatch (2) and open the filling hatch slowly until horizontal.

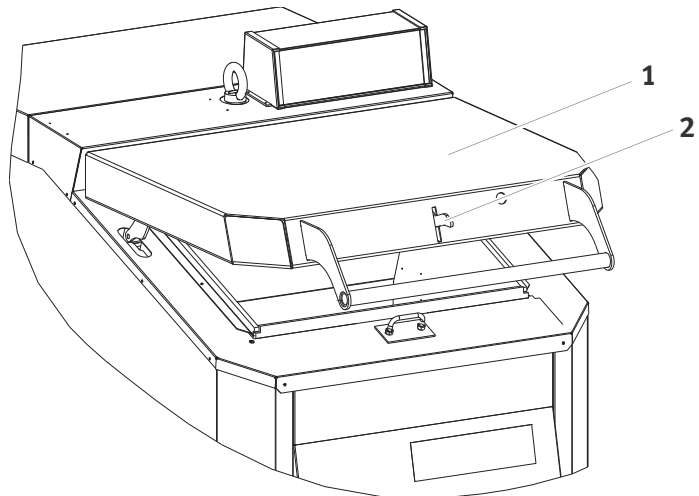

Figure 4/5 - Heating up / reloading

- ✓ The filling hatch opens automatically.

6. Use the cleaning tool (3) to remove the loose ash from the grate (2).

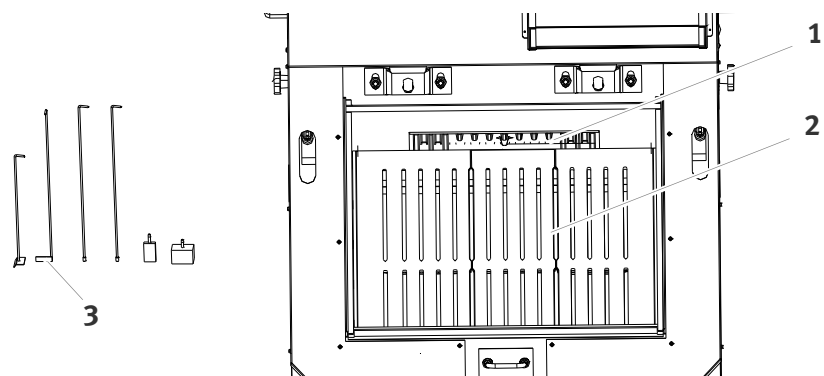

Figure 4/6 - Heating up / reloading

7. Leave any unburnt pieces of wood on the grate (2).
8. Place slightly flammable material (small, dry pieces of wood, paper, cardboard) in front of the burner nozzle (1) on the grate (2) and stack it 150 to 200 mm high.
9. Ignite it with a bit of newspaper.

10. As soon as the material is burning well, providing buffer temperature and heat intake capacity permit this, fill the fuel chamber (3) **up to 100 mm** below the fuel chamber top edge (2) with seasoned dry, split wood laid horizontally.

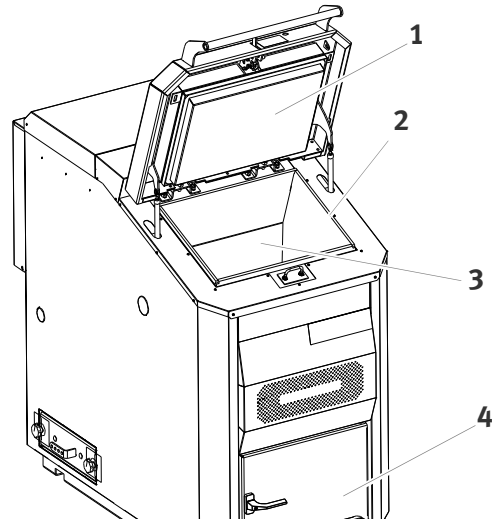

Figure 4/7 - Heating up / reloading

11. Close the filling hatch (1) and open the cleaning door (2).

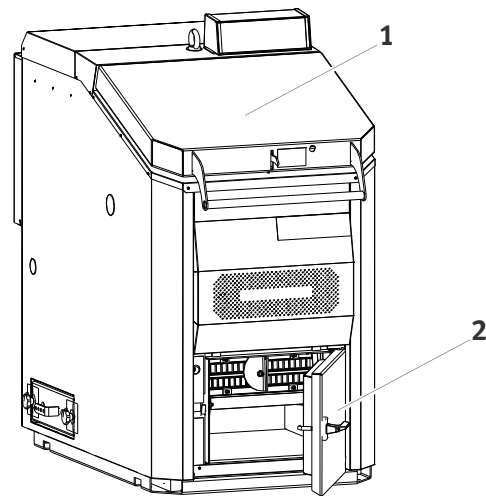

Figure 4/8 - Heating up / reloading

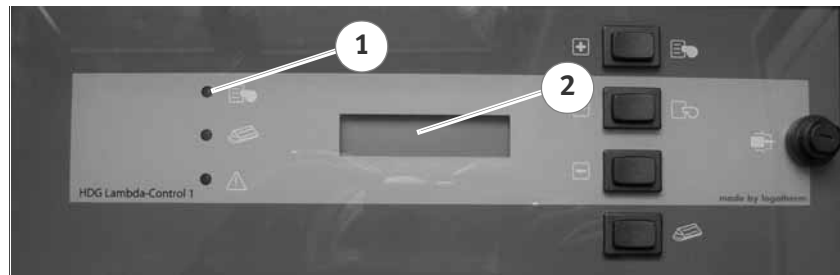

Figure 4/9 - Heating up / reloading

12. Hold the cleaning door open until the indicator lamp “Heat production on” (1) lights up and the message “**Heat production on**” appears in the display (2).
  - ✓ The indicator lamp “Heat production on” (1) lights up and the message “**Heat production on**” appears in the display (2).
13. Close the cleaning door.
  - 🔗 See number (2) Figure 4/8 - Heating up / reloading.
  - ✓ The boiler is now operating.

## RELOADING

Despite all precautions, the following residual risks remain:

**Caution!**

Hot surface.

Contact with the hot surfaces of the boiler can lead to burns.

Wait until the boiler has cooled down before touching uninsulated components.

**Warning!**

Danger of asphyxiation due to carbon monoxide.

If the boiler is operating, carbon monoxide can be emitted through the open filling hatch.

Do not leave the combustion chamber door and/or filling hatch open any longer than necessary.

**Caution!**

Danger of fire

Working in areas marked with this symbol can lead to a fire.

Do not leave the filling hatch open any longer than necessary.



Always check the integrity of the filling hatch seal before heating up the system.

**Caution!**

Hand injuries

Working in areas marked with this symbol can lead to hand injuries.

**Danger!**

Danger of explosion.

Work in areas marked with this symbol may only be performed exactly as specified by HDG Bavaria.

Improper operation can lead to explosions.

When the “Reload” indicator lights up, there are no more embers in the fuel chamber.

 See also section “4.1 Overview of the controls and display components”, paragraph “Control panel HDG Lambda Control 1” in this chapter.



1. Press the *Reload* button.

- ✓ The message **"Do not open, please wait"** appears in the display of the HDG Lambda Control system.
  - ✓ The flue fan starts to run.
  - ✓ After approx. 15 seconds, the message **"Unlock filling hatch"** appears.
2. Press the lock (2) of the filling hatch (1) downward.

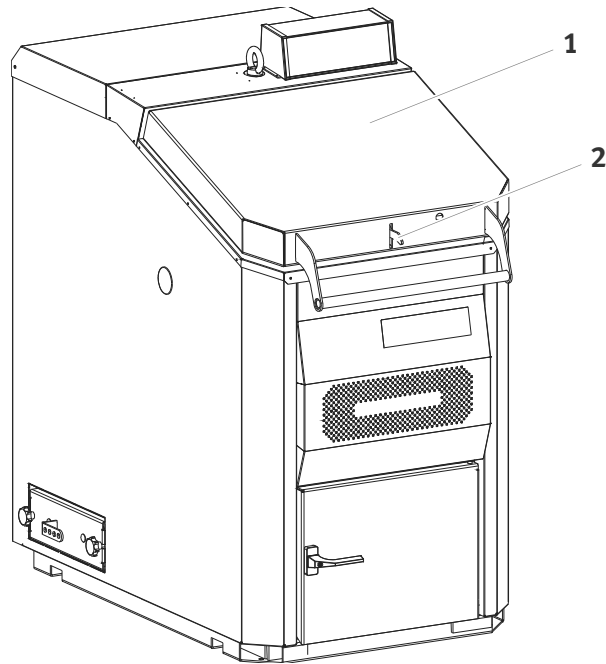

Figure 4/10 - Heating up / reloading

3. Raise the filling hatch (1) up to the stop.
4. Wait for approx. 10 seconds until the message **"Careful, open slowly"** appears.
5. Lift the lock of the filling hatch (1) and open the filling hatch slowly until horizontal.

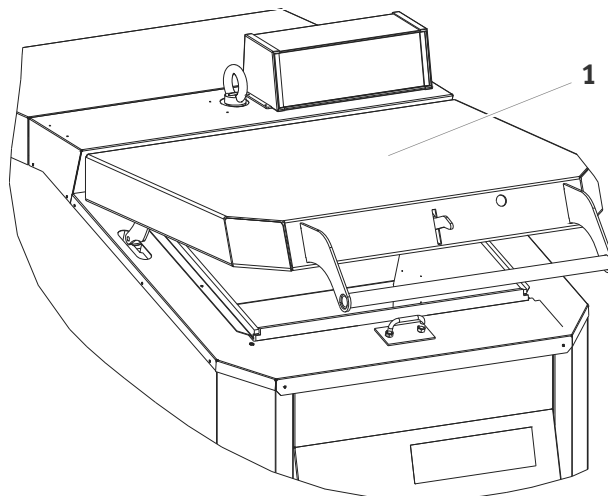

Figure 4/11 - Heating up / reloading

- ✓ The filling hatch opens automatically.

6. If a few residual embers are present, place small pieces of combustible material on the embers in the fuel chamber (3).
- ✓ The pieces of combustible material will ignite.
7. With an amount of seasoned dry wood that corresponds to the **potential heat intake capacity**, fill the fuel chamber (3) **up to maximally 100 mm** below the fuel chamber top edge (2).

**i**

Only refill with as much wood as the HDG Euro and accumulator can absorb as energy.

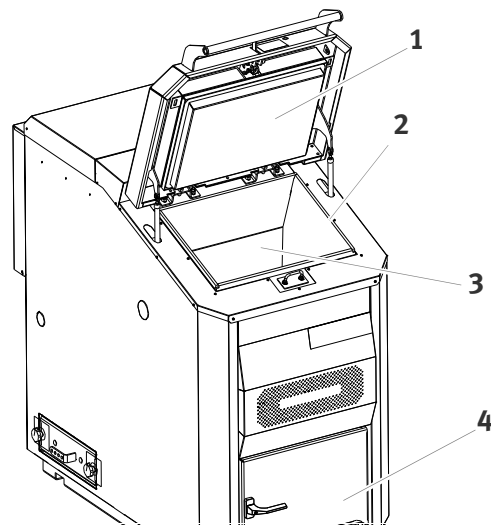

Figure 4/12 - Heating up / reloading

8. Close the filling hatch (1) and open the cleaning door (2).

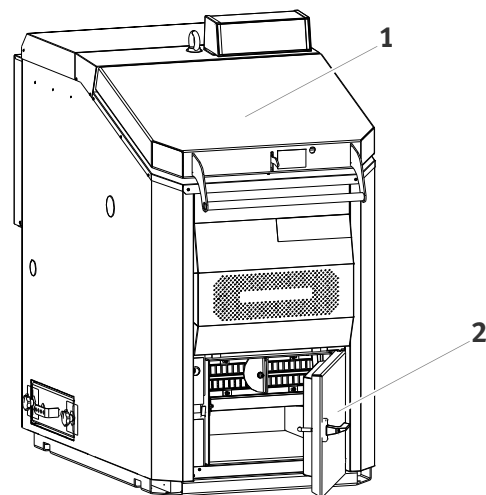

Figure 4/13 - Heating up / reloading

9. Hold the cleaning door open until the indicator lamp “Heat production on” (1) lights up and the message “**Heat production on**” appears in the display (2).

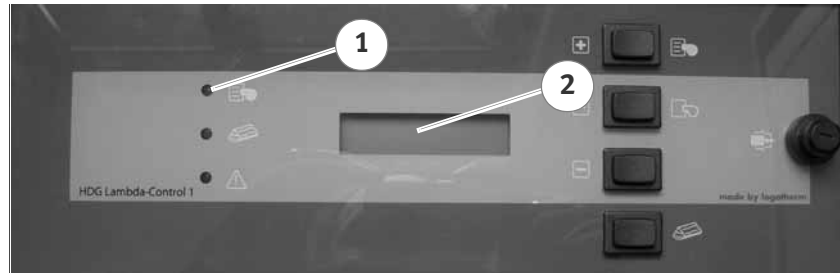

Figure 4/14 - Heating up / reloading

- ✓ The indicator lamp “Heat production on” (1) lights up and the message “**Heat production on**” appears in the display (2).
10. Close the cleaning door.
- ✎ See number (2) Figure 4/13 - Heating up / reloading.
  - ✓ The boiler is now heated.
  - ✎ See section “3.4 Fuel quality requirements” in chapter “3 Functional description”.

## 4.7 Switching off the HDG Euro for maintenance or repair work

1. Allow the fire in the HDG Euro to burn out.
- ✓ The boiler has burned out and the message “**Heat production off**” appears in the display.
2. Now switch off the emergency heating switch (if installed) or the corresponding breaker of the mains electricity supply.
- ✓ The HDG Euro is now switched off.



Only leave the system switched off as long as necessary, as the boiler protection program is disabled while without power.

# 5 Cleaning and maintaining the HDG Euro

To ensure fault-free operation, certain cleaning and maintenance work is necessary. This effort will help you avoid expensive repairs, providing you maintain the recommended intervals.

The biannual and longer term cleaning and maintenance work can be covered by a maintenance contract with an authorised heating engineer.

## 5.1 Cleaning and maintenance plan



The specified maintenance intervals are guidelines. These intervals may vary according to the quality of the fuel and the power used by the HDG Euro.

Interval	Component	See page ...
Weekly / as required	<ul style="list-style-type: none"> <li>Removing ash from fuel chamber and ash compartment</li> </ul>	41
Monthly (during the heating period, approx. 240 operating hours)	<ul style="list-style-type: none"> <li>Inspecting and cleaning downstream heating surfaces and combustion chamber</li> </ul>	44
	<ul style="list-style-type: none"> <li>Cleaning the burner nozzle</li> </ul>	58
Biannually (approx. 900 operating hours)	<ul style="list-style-type: none"> <li>Inspecting and cleaning the flue pipe</li> </ul>	46
	<ul style="list-style-type: none"> <li>Inspecting and cleaning the lambda sensor</li> </ul>	48
	<ul style="list-style-type: none"> <li>Inspecting and cleaning the flue gas sensor</li> </ul>	49
	<ul style="list-style-type: none"> <li>Inspecting and cleaning the flue fan</li> </ul>	50
	<ul style="list-style-type: none"> <li>Cleaning the primary air inlets</li> </ul>	57
Annually (approx. 1800 operating hours)	<ul style="list-style-type: none"> <li>Inspecting the pneumatic springs</li> </ul>	59
	<ul style="list-style-type: none"> <li>Inspecting and cleaning the fan unit</li> </ul>	51
	<ul style="list-style-type: none"> <li>Inspecting the integrity of the door seals</li> </ul>	52
	<ul style="list-style-type: none"> <li>Cleaning the control unit</li> </ul>	55
	<ul style="list-style-type: none"> <li>Calibrating the lambda sensor</li> </ul>	56

Table 5/1 - Cleaning and maintenance plan

## 5.2 How to proceed



### Warning!

Danger of asphyxiation due to carbon monoxide.

If the boiler is in operation, carbon monoxide can be emitted through the open doors.

Do not leave these open any longer than necessary.



The operating status of the HDG Euro must be indicated with “Heat production off” in the display of the HDG Lambda Control.

See section “4.1 Overview of the controls and display components” in chapter “4 Using the HDG Euro”



### Caution!

Danger of burns from hot surfaces.

During operation, the boiler surfaces under the cladding are hot. Even when turned off, they only cool down slowly.

Only touch the hot surfaces while wearing protective clothing or wait until the surfaces have cooled down before starting with the cleaning and maintenance work.



### Caution!

Danger of fire

Working in areas marked with this symbol can lead to a fire.

## CLEANING TOOLS

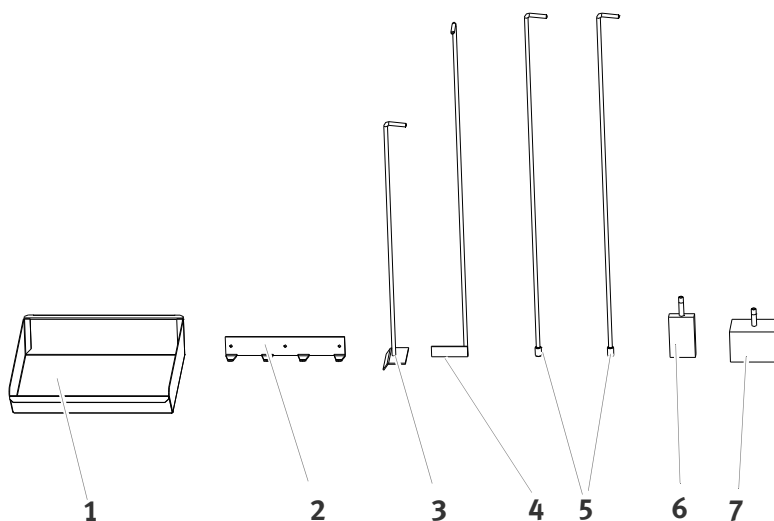

Figure 5/1 - Supplied cleaning tools

- 1 Ash pan
- 2 Tool holder
- 3 Scraper
- 4 Poker
- 5 Brush handle
- 6 Small brush
- 7 Large brush

### CLEANING THE FLAT GRATE AND ASH COMPARTMENT

1. Allow the fire in the boiler to burn out.



The operating status of the HDG Euro must be indicated with **“Heat production off”** in the display of the HDG Lambda Control.

 See section “4.1 Overview of the controls and display components” in chapter “4 Using the HDG Euro”.



#### Caution!

Danger of burns from hot surfaces.

The surfaces of the boiler can be hot. Even when turned off, they only cool down slowly.

Do not start with the maintenance work until the surfaces have cooled down.



2. Press the **“Reload”** button.

- ✓ The message **"Do not open, please wait"** appears in the display of the HDG Lambda Control system.
  - ✓ The flue fan starts to run.
  - ✓ After approx. 15 seconds, the message **"Unlock filling hatch"** appears.
3. Press the lock (2) of the filling hatch (1) downward.

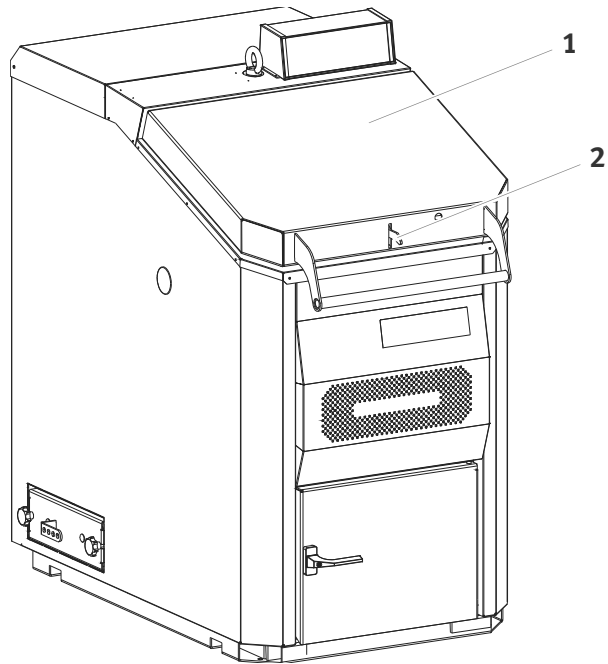

Figure 5/2 - Cleaning the flat grate and ash compartment

4. Raise the filling hatch (1) up to the stop.
5. Wait for approx. 10 seconds until the message **"Careful, open slowly"** appears.
6. Lift the lock of the filling hatch (1) and open the filling hatch slowly until horizontal.

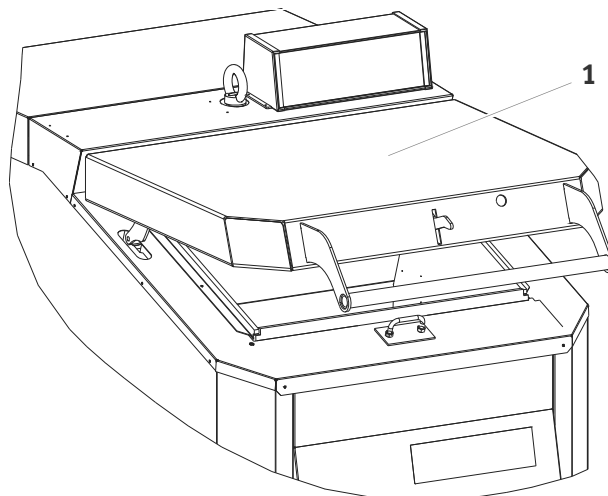

Figure 5/3 - Cleaning the flat grate and ash compartment

- ✓ The filling hatch opens automatically.

7. Use the supplied cleaning tool to remove the loose ash from the grate (2). Ensure the ash from the corners of the fuelling chamber are cleaned each time.
8. Leave any unburnt pieces of wood and charcoal in the fuel chamber (1).
9. Open the cleaning door (3).

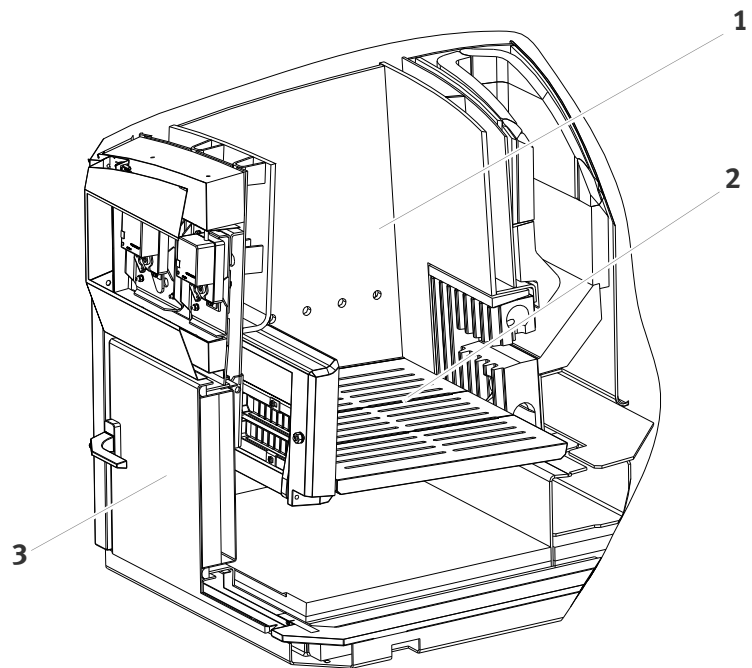

Figure 5/4 - Cleaning the flat grate and ash compartment

10. Place the ash pan (2) in front of the ash compartment (1).

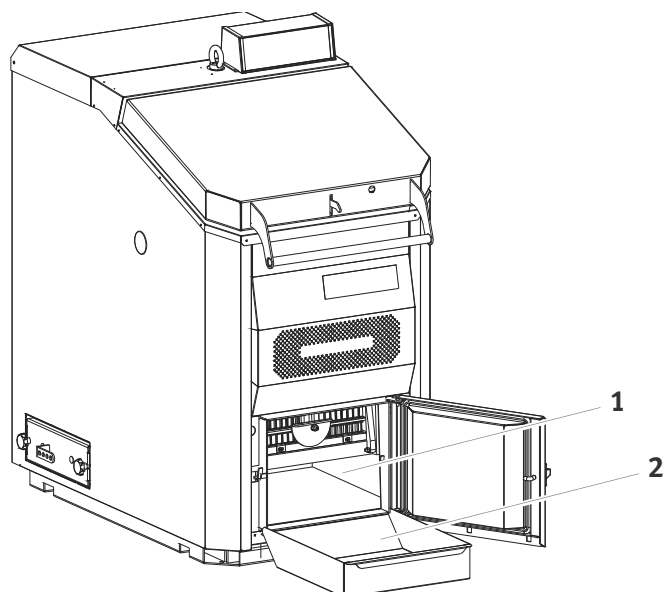

Figure 5/5 - Cleaning the flat grate and ash compartment

11. Use the scraper to sweep the ash into the ash pan (2).



**Caution!**

**Danger of fire**

Do not place hot ash in flammable receptacles!

12. Close the boiler in the reverse sequence.
  13. After it has cooled, dispose of the ash together with household refuse.
- ✓ The combustion residues are removed from the ash compartment and from the grate.

**INSPECTING AND CLEANING DOWNSTREAM HEATING SURFACES AND COMBUSTION CHAMBER**

1. Allow the fire in the boiler to burn out.



The operating status of the HDG Euro must be indicated with “**H**eat **p**roduction **o**ff” in the display of the HDG Lambda Control.

 See section “4.1 Overview of the controls and display components” in chapter “4 Using the HDG Euro”.



**Caution!**

Danger of burns from hot surfaces.

The surfaces of the boiler can be hot. Even when turned off, they only cool down slowly.

Do not start with the maintenance work until the surfaces have cooled down.

2. Remove the upper cladding (1) by lifting it upward.

3. Open the upper cleaning door (2).

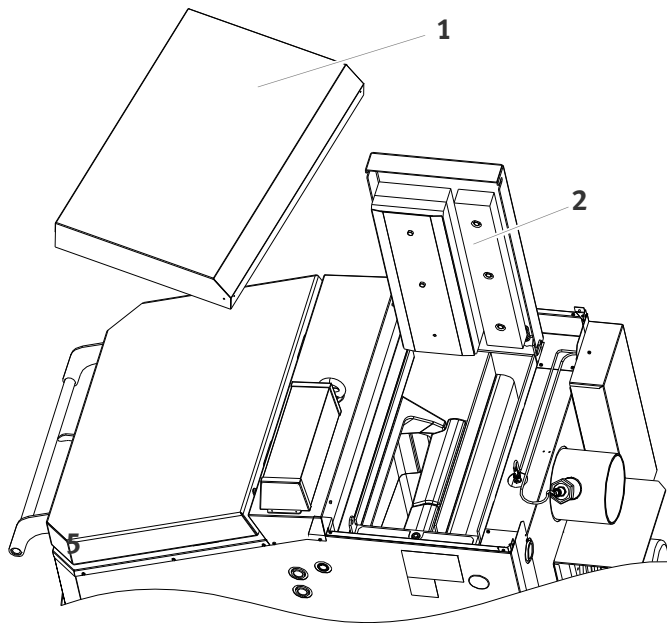

Figure 5/6 - Cleaning the burner nozzle

4. Pull out the flue gas deflector plate (1) in an upward direction.

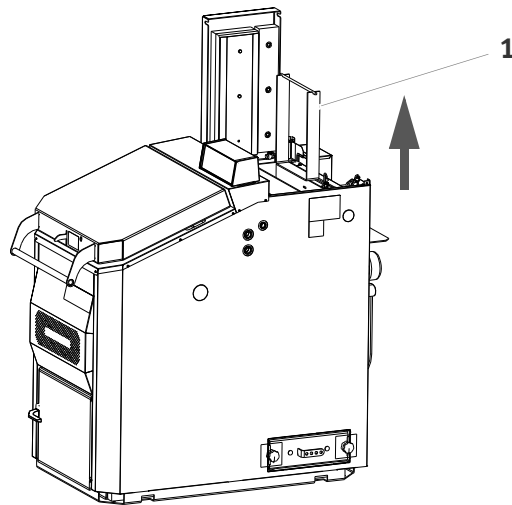

Figure 5/7 - Cleaning the burner nozzle

5. Clean off the downstream heating surfaces (1) as needed with the small and large cleaning brushes.

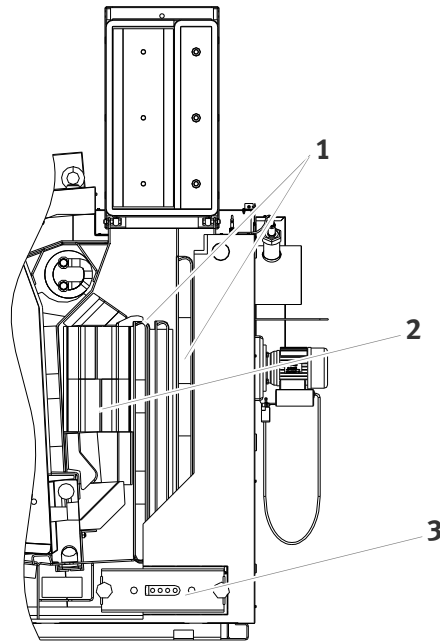

Figure 5/8 - Cleaning the burner nozzle

6. Take off one of the cleaning doors (3) from either the right or left side of the boiler and remove the fly ash with a suitable tool.
7. Use a suitable vacuum cleaner to remove any deposits and dust in the area of the combustion chamber (2).



**Caution!**

**Danger of fire**

Do not use the vacuum cleaner if the ash is still hot and do not place hot ash in flammable containers.

8. Close the boiler in the reverse sequence.
- ✓ The inspection and cleaning of the downstream heating surfaces and combustion chamber is completed.

**INSPECTING AND CLEANING THE FLUE PIPE**

1. Allow the fire in the boiler to burn out.



The operating status of the HDG Euro must be indicated with “**H**eat **p**roduction **o**ff” in the display of the HDG Lambda Control.

🔗 See section “4.1 Overview of the controls and display components” in chapter “4 Using the HDG Euro”.

2. Allow the boiler and the flue pipe (3) to cool down.
3. Unscrew the wing nut (1) on the inspection hatch (2).

**Caution!**

Danger of burns from hot surfaces.

The surfaces of the boiler can be hot. Even when turned off, they only cool down slowly.

Do not start with the maintenance work until the surfaces have cooled down.

4. Remove the inspection hatch (2) from the flue pipe (3).
5. Check whether the flue pipe requires cleaning.
6. If necessary, use a suitable vacuum cleaner to clean out the flue pipe (3).
7. Sweep any deposits into the flue gas collection box, but not in the direction of the boiler.

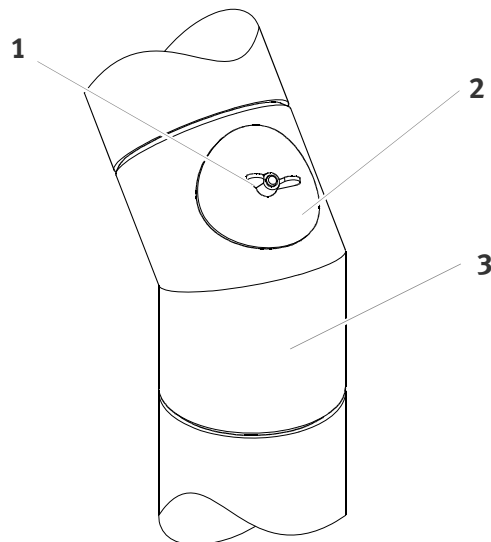

Figure 5/9 - Cleaning the flue pipe

8. Refit the inspection hatch (2) securely onto the flue pipe (3) with the wing nut (1).

✓ The cleaning of the flue pipe is completed.



Your flue connection configuration may not match the information above. Your installer will have provided access to clean the boiler's flue outlet and the chimney system.

### INSPECTING AND CLEANING THE LAMBDA SENSOR

1. Allow the fire in the boiler to burn out.



The operating status of the HDG Euro must be indicated with “**H**eat **p**roduction **o**ff” in the display of the HDG Lambda Control.

See section “4.1 Overview of the controls and display components” in chapter “4 Using the HDG Euro”.



#### Caution!

Danger of burns from hot surfaces.

The surfaces of the boiler can be hot. Even when turned off, they only cool down slowly.

Do not start with the maintenance work until the surfaces have cooled down.

2. Unscrew the union nut (1) with a pipe wrench.

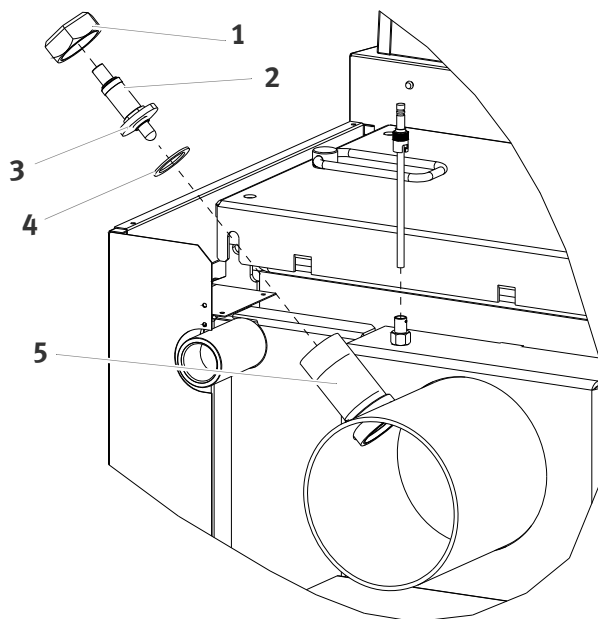

Figure 5/10 - Cleaning the lambda sensor

3. Remove the lambda sensor (2), including the insulating washer (3) and the seal (4), from the installation fitting (5).
4. Brush off the lambda sensor (2) with a **brass brush**.



Do not use steel bristles!

Steel bristles will **damage** the lambda sensor.

5. Clean out any deposits found inside the installation fitting (5).
6. Reinstall the lambda sensor (2) in the reverse sequence.



### Tightness

When reinstalling the lambda sensor, make sure its seal is intact. Use a pipe wrench to tighten the union nut (1). Do not overtighten! Never tighten the lambda sensor by the shaft body.

✓ The cleaning of the lambda sensor is completed.

### INSPECTING AND CLEANING THE FLUE GAS SENSOR

1. Allow the fire in the boiler to burn out.



The operating status of the HDG Euro must be indicated with “**Heat production off**” in the display of the HDG Lambda Control.

🔧 See section “4.1 Overview of the controls and display components” in chapter “4 Using the HDG Euro”.



### Caution!

Danger of burns from hot surfaces.

The surfaces of the boiler can be hot. Even when turned off, they only cool down slowly.

Do not start with the maintenance work until the surfaces have cooled down.

2. Using light pressure, rotate the flue gas sensor (1) downwards one quarter turn in an anticlockwise direction.

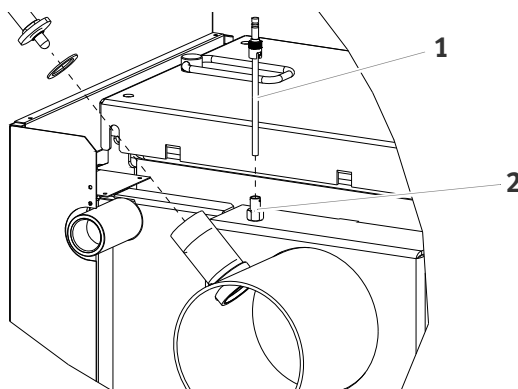

Figure 5/11 - Cleaning the flue gas sensor

3. Pull the flue gas sensor (1) out of the holder (2).

4. Clean the sensor surface.

5. Reinstall the flue gas sensor (1) in the reverse sequence.

✓ The cleaning of the flue gas sensor is completed.

### INSPECTING AND CLEANING THE FLUE FAN

1. Allow the fire in the boiler to burn out.



The operating status of the HDG Euro must be indicated with “**H**eat **p**roduction **o**ff” in the display of the HDG Lambda Control.

 See section “4.1 Overview of the controls and display components” in chapter “4 Using the HDG Euro”.



#### Caution!

Danger of burns from hot surfaces.

The surfaces of the boiler can be hot. Even when turned off, they only cool down slowly.

Do not start with the maintenance work until the surfaces have cooled down.



#### Caution!

Hand injuries

Working in areas marked with this symbol can lead to hand injuries.

2. Disconnect the plug (1) from the flue fan (2).
3. Use a 13 mm hand ratchet to unscrew the four M8 nuts (3).

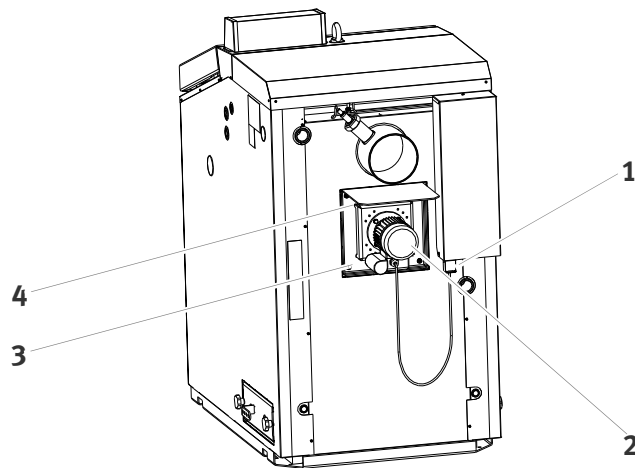

Figure 5/12 - Cleaning the flue fan

4. Remove the exhaust fan (2), including the flange plate (4), from the boiler.

5. Clean the flue gas collection box (1).

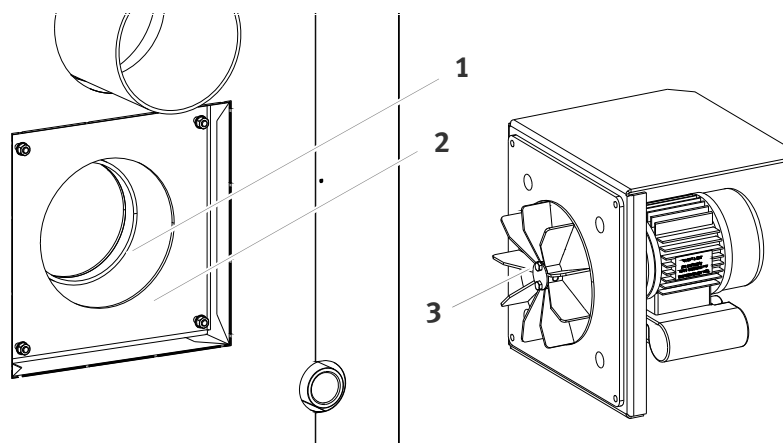

Figure 5/13 - Cleaning the flue fan

6. Clean the impeller (3) and the piston ring behind the fan wheel (3) with a brass brush.
7. Inspect the seal and the contact surfaces around the flue fan (2) and the flue gas collection box (1).
8. Replace the seal if it is damaged. Order number of gasket.
9. Reinstall the flue fan in the reverse sequence.
- ✓ The cleaning of the flue fan is completed.

#### INSPECTING AND CLEANING THE FAN UNIT

1. Allow the fire in the boiler to burn out.



The operating status of the HDG Euro must be indicated with **“Heat production off”** in the display of the HDG Lambda Control.

✎ See section “4.1 Overview of the controls and display components” in chapter “4 Using the HDG Euro”.



#### Caution!

Danger of burns from hot surfaces.

The surfaces of the boiler can be hot. Even when turned off, they only cool down slowly.

Do not start with the maintenance work until the surfaces have cooled down.

2. Lift up on the cladding (2) of the fan unit (1) and pull it out towards the front.

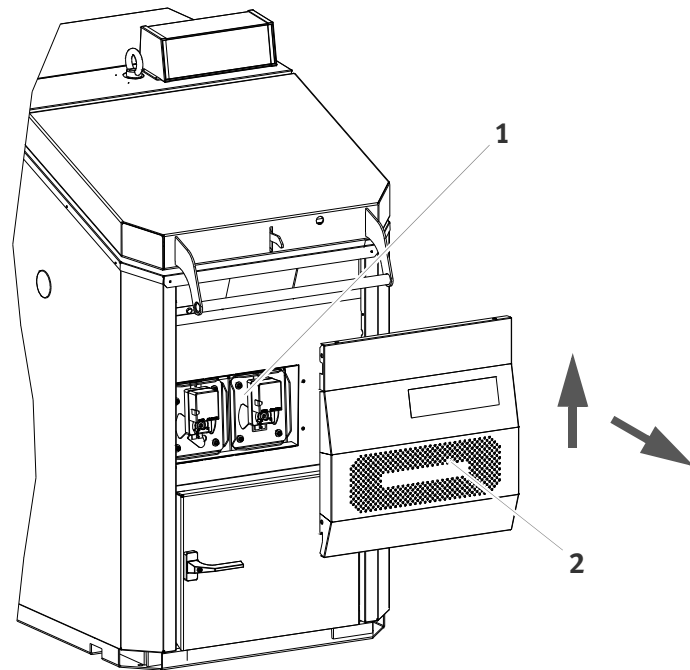

Figure 5/14 - Cleaning the fan unit

3. Use a fine brush and a vacuum cleaner to remove dust deposits from the fan unit (1).
  4. Close the fan unit in the reverse sequence.
- ✓ The cleaning of the fan unit is completed.

### INSPECTING THE INTEGRITY OF THE DOOR SEALS

#### INSPECTING THE FILLING HATCH

1. Allow the fire in the boiler to burn out.



The operating status of the HDG Euro must be indicated with “**Heat production off**” in the display of the HDG Lambda Control.

📎 See section “4.1 Overview of the controls and display components” in chapter “4 Using the HDG Euro”.



#### Caution!

Danger of burns from hot surfaces.

The surfaces of the boiler can be hot. Even when turned off, they only cool down slowly.

Do not start with the maintenance work until the surfaces have cooled down.



2. Press the “Reload” button.
3. Open the filling hatch (1)
4. Clamp a sheet of paper (approx. 300 mm long and 20 m wide) between the contact surface (2) and filling hatch seal.
5. Close the filling hatch (1).
6. Pull on the paper.

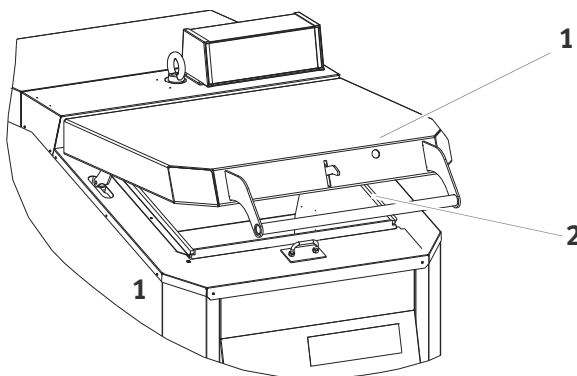

Figure 5/15 - Inspecting the door seals

- ✓ If the paper moves, the door is not properly sealed.
- ✓ If the paper does not move, the door is properly sealed.



If the filling hatch does not seal properly, contact a specialist to have it repaired.

7. Repeat the procedure from step 2 to step 5 until you have inspected all four of the contact surfaces (2).
  8. Remove the paper and close the filling hatch (1).
  - ✓ The inspection of the filling hatch seal is completed.
1. Allow the fire in the boiler to burn out.

#### INSPECTING THE ASH DOOR



The operating status of the HDG Euro must be indicated with “**Heat production off**” in the display of the HDG Lambda Control.

🔗 See section “4.1 Overview of the controls and display components” in chapter “4 Using the HDG Euro”.



#### Caution!

Danger of burns from hot surfaces.

The surfaces of the boiler can be hot. Even when turned off, they only cool down slowly.

Do not start with the maintenance work until the surfaces have cooled down.



2. Press the “Reload” button.
3. Open the ash door (1).
4. Proceed as described under Inspecting the filling hatch in this chapter.

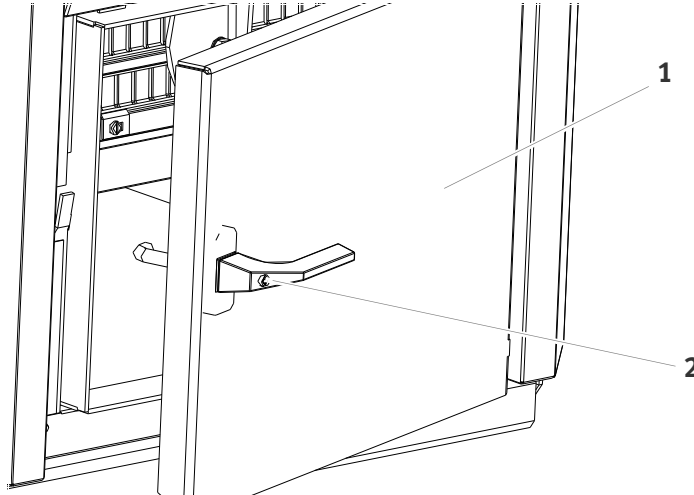

Figure 5/16 - Inspecting the door seals

5. If the door is not properly sealed, tighten the hexagon head screw (2) slightly.
6. Inspect again.
- ✓ The ash door is sealed.
7. Close the ash door again properly.
- ✓ The inspection of the ash door is completed.

#### INSPECTING THE CLEANING DOOR

1. Remove the upper cladding (1) by lifting it upward.

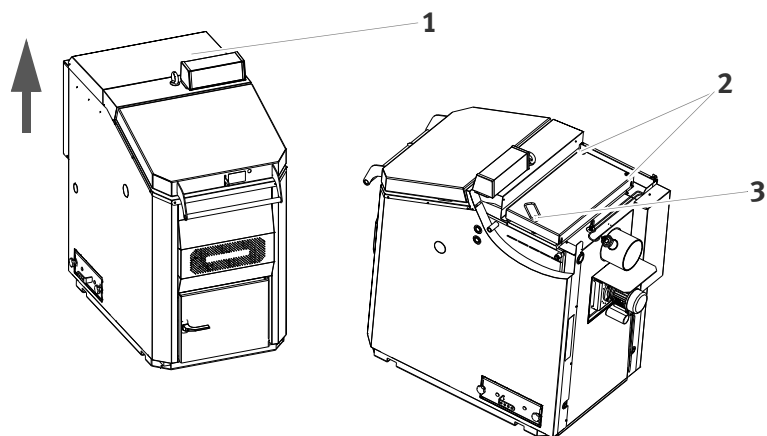

Figure 5/17 - Inspecting the door seals

2. Proceed as described under Inspecting the filling hatch in this chapter.
3. If the seal is not tight, use a 19 mm fork wrench to tighten the hexagon head nut (2) one turn.

4. Inspect again.
  - ✓ The cleaning door is sealed.
5. Close the cleaning door again properly.
  - ✓ The inspection of the cleaning door is completed.

#### CLEANING THE CONTROL UNIT

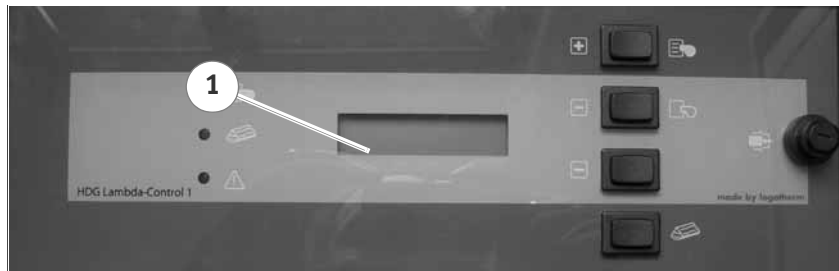

Figure 5/18 - Cleaning the HDG Lambda Control 1 control unit

1. Clean the control unit with a moist, lint-free cloth.
  2. For stubborn dirt, use a mild cleaning agent.
  3. Dry the control unit with a soft cloth.
- ✓ The cleaning of the control unit is completed.

### CALIBRATING THE LAMBDA SENSOR

1. Allow the fire in the boiler to burn out.



The operating status of the HDG Euro must be indicated with “**Heat production off**” in the display of the HDG Lambda Control.

**No residual embers should be in the fuel chamber!**

 See section “4.1 Overview of the controls and display components” in chapter “4 Using the HDG Euro”.



2. Press the *Arrow* button.

✓ The “**Selection/information**” message will appear in the display.



3. Press the *Plus* button twice.

✓ The message “**Selection / component test**” appears in the display.



4. Press the *Arrow* button.

✓ The message “**Test O<sub>2</sub> sensor**” appears in the display.



5. Press the *Plus* button.

✓ The calibration of the lambda sensor starts. The runtime is **720** seconds.

✓ When the sensor test is complete, the message “**Sensor okay**” appears in the display.

✓ The lambda sensor is calibrated.



If the “**Sensor defective**” message appears in the display, have the fault rectified by a qualified electrician or an authorised HDG installer.



6. Press the *Plus* and *Minus* buttons simultaneously.

✓ The system component test menu closes.

### CLEANING THE PRIMARY AIR INLETS

1. Allow the fire in the boiler to burn out.



The operating status of the HDG Euro must be indicated with “**Heat production off**” in the display of the HDG Lambda Control.

See section “4.1 Overview of the controls and display components” in chapter “4 Using the HDG Euro”.



#### Caution!

Danger of burns from hot surfaces.

The surfaces of the boiler can be hot. Even when turned off, they only cool down slowly.

Do not start with the maintenance work until the surfaces have cooled down.



2. Press the “Reload” button.
3. Open the filling hatch (1).

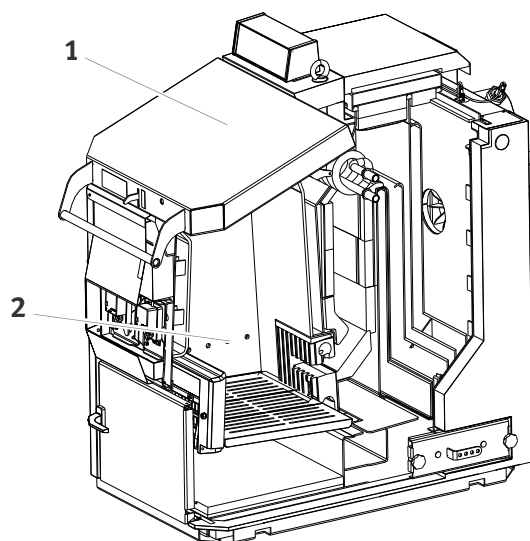

Figure 5/19 - Cleaning the primary air inlets

4. Use a suitable tool to clean the primary air inlets of dirt.
  5. Vacuum each primary air inlet with a vacuum cleaner until cleared.
  6. Close the boiler in the reverse sequence.
- ✓ The cleaning of the primary air inlets is completed.

### CLEANING THE BURNER NOZZLE

1. Allow the fire in the boiler to burn out.



The operating status of the HDG Euro must be indicated with “**H**eat **p**roduction **o**ff” in the display of the HDG Lambda Control.

 See section “4.1 Overview of the controls and display components” in chapter “4 Using the HDG Euro”.



#### Caution!

Danger of burns from hot surfaces.

The surfaces of the boiler can be hot. Even when turned off, they only cool down slowly.

Do not start with the maintenance work until the surfaces have cooled down.



2. Press the “Reload” button.
3. Open the ash door (3).

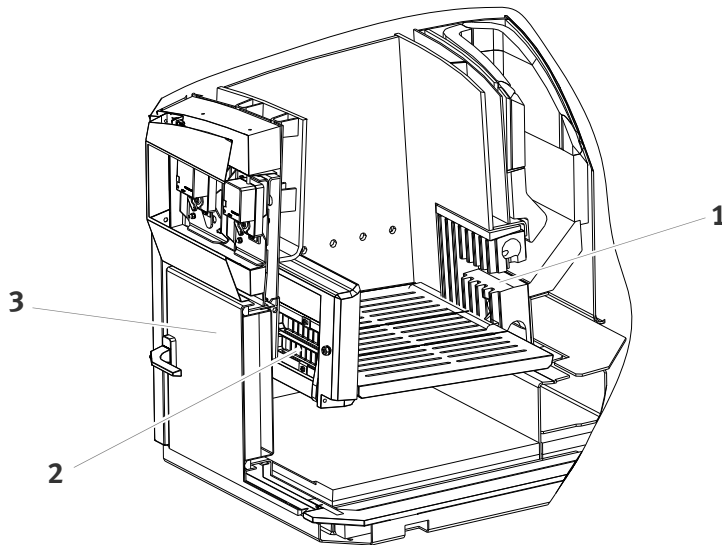

Figure 5/20 - Cleaning the burner nozzle

4. Open the cleaning flap (2).
5. Clean the burner nozzle (1) with a suitable vacuum cleaner.



#### Caution!

#### Danger of fire

Do not use the vacuum cleaner if the ash is still hot and do not place hot ash in flammable containers.

6. Close the boiler again properly.
- ✓ The cleaning of the burner nozzle is completed.

### INSPECTING THE PNEUMATIC SPRINGS

1. Allow the fire in the boiler to burn out.



The operating status of the HDG Euro must be indicated with **“Heat production off”** in the display of the HDG Lambda Control.

 See section “4.1 Overview of the controls and display components” in chapter “4 Using the HDG Euro”.



#### Caution!

Hand injuries

Working in areas marked with this symbol can lead to hand injuries.



#### Caution!

Danger of burns from hot surfaces.

The surfaces of the boiler can be hot. Even when turned off, they only cool down slowly.

Do not start with the maintenance work until the surfaces have cooled down.



2. Press the **“Reload”** button.

✓ The message **“Do not open, please wait”** appears in the display of the HDG Lambda Control system.

✓ The flue fan starts to run.

✓ After approx. 15 seconds, the message **“Unlock filling hatch”** appears.

3. Press the lock (2) of the filling hatch (1) downward.

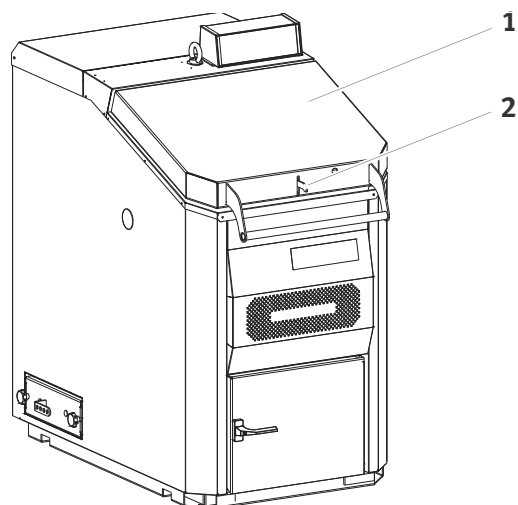

Figure 5/21 - Inspecting the pneumatic springs

4. Raise the filling hatch (1) up to the stop.

5. Wait for approx. 10 seconds until the message **"Careful, open slowly"** appears.
6. Lift the lock of the filling hatch (1) and open the filling hatch slowly until horizontal.

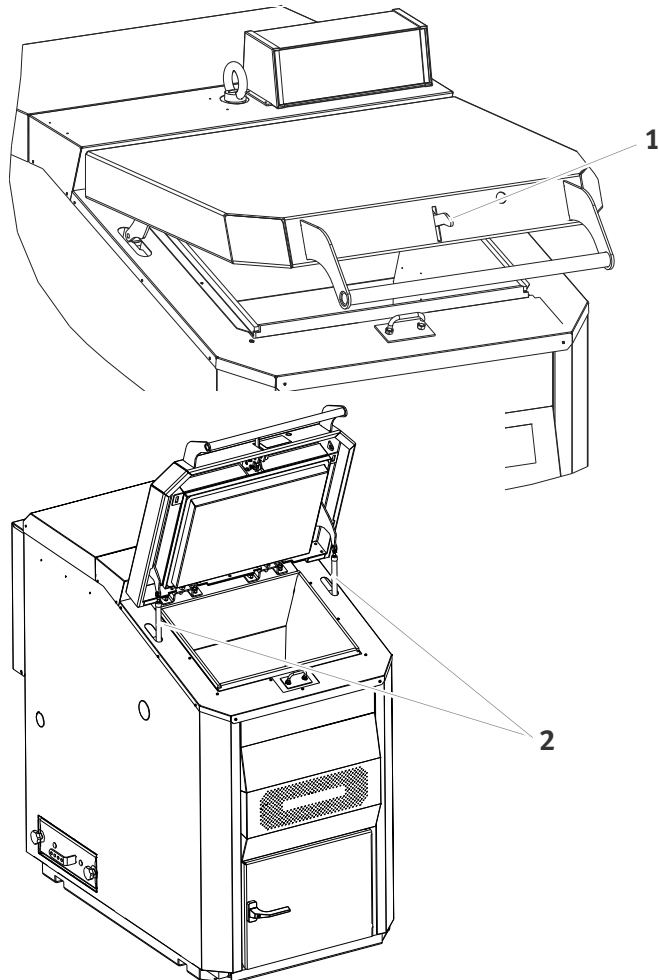

Figure 5/22 - Inspecting the pneumatic springs

- ✓ If the filling hatch opens quickly from the horizontal position, the pneumatic springs (2) are OK.
  - ✓ If the filling hatch does not open from the horizontal position or has to be lifted, the pneumatic springs (2) must be replaced.
7. Close the log wood boiler.
- ✓ The pneumatic spring inspection is completed.

# 6 Troubleshooting

If a fault occurs in the HDG Euro, it will be indicated in the display of the HDG Lambda Control 1 and by the indicator lamp on the HDG Lambda Control 1 control panel.

Faults are broken down into two types:

- Faults which permit the heating process to continue
  - The fault indicator lamp on the control panel of the HDG Lambda Control 1 flashes
- Faults which do not permit the heating process to continue
  - The fault indicator lamp on the control panel of the HDG Lambda Control 1 remains continuously lit

 See chapter “4 Using the HDG Euro”, section “Control panel HDG Lambda Control 1”

## 6.1 How to proceed

1. Look for the displayed fault's cause and remedy in Table 6/1 - Faults with flashing indicator lamp.
  2. Eliminate the fault or have it repaired by an authorised electrician.
  3. Acknowledge the fault with the *Arrow* button.
- ✓ The fault will be cleared from the display.



## 6.2 Possible faults

### FAULTS WHICH DO NOT INTERRUPT THE PRODUCTION OF HEAT

The fault indicator lamp on the control panel of the HDG Lambda Control 1 flashes.

Fault message	Cause	Remedy
Incorrect oxygen level reading  Sensor is worn out or needs cleaning  Plug/cable  Controller is faulty	<ul style="list-style-type: none"> <li>• Lambda sensor is worn out or needs cleaning</li> </ul>	<ul style="list-style-type: none"> <li>• Clean and then calibrate the lambda sensor</li> <li>✎ See chapter “5 Cleaning and maintaining the HDG Euro”</li> <li>• Can only be reset by calibrating</li> </ul>
Buffer temp. reading incorrect  Plug/cable Sensor is faulty  Controller is faulty	<ul style="list-style-type: none"> <li>• Sensor is faulty</li> <li>• Contact broken</li> <li>• Controller is faulty</li> </ul>	<ul style="list-style-type: none"> <li>• Have the fault fixed by an authorised installer</li> <li>• Automatically reset after fault is eliminated</li> </ul>
Return temp. reading incorrect  Plug/cable Sensor is faulty  Controller is faulty <b>(For system 5 only)</b>	<ul style="list-style-type: none"> <li>• Sensor is faulty</li> <li>• Contact broken</li> <li>• Controller is faulty</li> </ul>	<ul style="list-style-type: none"> <li>• Have the fault fixed by an authorised installer</li> <li>• Automatically reset after fault is eliminated</li> </ul>
Boiler temperature too low  Return valve Plug/cable Motor/controller	<ul style="list-style-type: none"> <li>• Sensor is faulty</li> <li>• Contact broken</li> <li>• Controller is faulty</li> <li>• Return valve</li> </ul>	<ul style="list-style-type: none"> <li>• Have the fault fixed by an authorised installer</li> <li>• Reset by pressing the <i>Arrow</i> button</li> </ul>

Table 6/1 - Faults with flashing indicator lamp



### FAULTS WHICH INTERRUPT THE PRODUCTION OF HEAT

The fault indicator lamp on the control panel of the HDG Lambda Control 1 remains continuously lit.

Fault message	Cause	Remedy
STB is triggered - Reset  Insufficient heat extraction! Pumps/valves	<ul style="list-style-type: none"> <li>• Safety temperature limiter triggered</li> </ul>	<ul style="list-style-type: none"> <li>• Have the fault repaired by an authorised installer</li> </ul>
Incorrect flue gas temperature reading  Plug/cable Sensor is faulty  Controller is faulty	<ul style="list-style-type: none"> <li>• Sensor is faulty</li> <li>• Contact broken</li> <li>• Controller is faulty</li> </ul> (flue gas temperature above 300 °C, cleaning door open, door seal defective, fire in flue)	<ul style="list-style-type: none"> <li>• Have the fault repaired by an authorised installer</li> </ul>
Boiler temperature reading incorrect  Plug/cable Sensor is faulty  Controller is faulty	<ul style="list-style-type: none"> <li>• Sensor is faulty</li> <li>• Contact broken</li> <li>• Controller is faulty</li> </ul>	<ul style="list-style-type: none"> <li>• Have the fault repaired by an authorised installer</li> </ul>
Data loss  Controller is faulty	<ul style="list-style-type: none"> <li>• Controller is faulty</li> </ul>	<ul style="list-style-type: none"> <li>• Have the fault repaired by an authorised installer</li> </ul>

Table 6/2 - Faults which cause indicator lamp to stay on

# 7 Commissioning the HDG Euro

The HDG Euro will initially be commissioned by specialists from HDG Bavaria or from an authorised HDG partner.

The commissioning includes an introduction to the operation and maintenance of the HDG Euro as well as the taking of measurements on the system for pollution and heating capacity.



---

## **Danger!**

Material damage and injury due to incorrect commissioning.

Commissioning the system requires comprehensive specialist knowledge. If this commissioning is done by an untrained person, the HDG Euro can be damaged.

Only allow authorised specialists to perform the commissioning.

---

## 7.1 Conditions

The following requirements must be met to ensure there are no problems during commissioning.









- The HDG Euro has been filled with water as specified.
- The HDG Euro has been deaerated.
- The pressure of the membrane expansion container has been adapted to on-site conditions.
- All required DIN EN 12828 safety devices have been installed and are ready for operation.
- The supply of power to all components has been provided (makeshift solutions are not sufficient).
- The chimney installation corresponds to the legal regulations.
- All doors and openings on the boiler and on the chimney connection duct have been checked for a proper seal.
- Air supply for combustion has been provided.
- A sufficient amount of fuel is available.

## 7.2 Commissioning the HDG Euro

### SWITCHING HDG EURO ON

1. Switch on the circuit breaker for the mains electricity supply, or otherwise ensure the unit is provided with power.
2. Turn on the emergency heating switch (if one has been installed).
  - ✓ There is now electrical power in the HDG Euro.
  - ✓ The indicator lamp in the emergency heating switch will light up.
  - ✓ The control is activated.
  - ✓ The controller self test is activated.
  - ✓ The message “**Enter code**” appears in the display.

### CONFIGURING THE CONTROL

- |                  |                                                                                                                                                                                                                                                                   |                                                                                                                                                                                                                                                                                                                                                                                                                                                                                                                                                                                                                                                                                                                                                                                                                                                                              |
|------------------|-------------------------------------------------------------------------------------------------------------------------------------------------------------------------------------------------------------------------------------------------------------------|------------------------------------------------------------------------------------------------------------------------------------------------------------------------------------------------------------------------------------------------------------------------------------------------------------------------------------------------------------------------------------------------------------------------------------------------------------------------------------------------------------------------------------------------------------------------------------------------------------------------------------------------------------------------------------------------------------------------------------------------------------------------------------------------------------------------------------------------------------------------------|
| LANGUAGE         | <br>                                                                                         | <ol style="list-style-type: none"> <li>1. Press the <i>Plus</i> button.</li> <li>✓ The value of the displayed code will be increased by one.</li> <li>2. Confirm the value with the <i>Arrow</i> button.</li> <li>✓ The message “<b>Language [D] Deutsch</b>” appears in the display.</li> </ol>                                                                                                                                                                                                                                                                                                                                                                                                                                                                                                                                                                             |
| BOILER TYPE      | <br><br> | <ol style="list-style-type: none"> <li>3. Use the <i>Plus</i> or <i>Minus</i> button to select the desired language.</li> <li>✓ The selected language will appear in the display.</li> <li>4. Confirm using the <i>Arrow</i> button.</li> <li>✓ The language is set and the menu will advance to the next setting.</li> <li>✓ The message “<b>Boiler type HDG Euro..</b>” appears in the display.</li> <li>5. Read off the boiler type from the name plate on the boiler.</li> <li>6. Use the <i>Plus</i> or <i>Minus</i> button to select the appropriate boiler type.</li> <li>✓ The selected boiler type will appear in the display.</li> <li>7. Confirm using the <i>Arrow</i> button.</li> <li>✓ The boiler type is set and the menu will advance to the next setting.</li> <li>✓ The following message appears in the display:<br/>“<b>System no. : 0</b>”.</li> </ol> |
| HYDRAULIC SYSTEM | <br><br> | <ol style="list-style-type: none"> <li>8. Use the <i>Plus</i> or <i>Minus</i> button to select the appropriate hydraulic system.</li> <li>✓ The selected hydraulic system will appear in the display.</li> <li>9. Confirm using the <i>Arrow</i> button.</li> </ol>                                                                                                                                                                                                                                                                                                                                                                                                                                                                                                                                                                                                          |



Refer to the planning and installation documentation to determine the specific hydraulic system.

✓ The message “**Are you sure?**” appears in the display.



10. Press the *Arrow* button to confirm.

✓ The hydraulic system is set and the menu will advance to the next setting.



11. Press the *Minus* button if you are not sure.

✓ The menu will return to the hydraulic system selection window.

12. Select another hydraulic system and proceed as instructed in **step 10**.

✓ The hydraulic system is set and the menu will advance to the next setting.

✓ The message “**Buffer tank sensor: yes?**” appears in the display.

#### BUFFER TANK SENSOR



13. Use the *Plus* or *Minus* button to select the setting “**Yes**” or “**No**”.

✓ The selected setting will appear in the display.



14. Confirm using the *Arrow* button.

✓ The setting is stored and the menu will advance to the next setting.



“Buffer tank sensor in [m] 8” will only appear if the “Buffer tank sensor: yes” setting was selected.

#### CABLE LENGTH OF THE BUFFER TANK SENSOR

✓ The message “**Buffer tank sensor length in [m] 8**” appears in the display.



15. Use the *Plus* or *Minus* button to select the actual cable length to ensure that correct values will be obtained for the temperature readings.

✓ The corresponding value will appear in the display.



16. Confirm using the *Arrow* button.

✓ The cable length is set and the menu will advance to the next setting.

#### MINIMUM BUFFER TANK TEMPERATURE

✓ The message “**Min. buffer tank TS<sub>min</sub> [°C] 45**” appears in the display.



17. Use the *Plus* or *Minus* button to select the desired minimum buffer tank temperature for load balancing, accumulator or energy store.



If the preset minimum temperature is not achieved, the “Reload” indicator is activated and the oil or gas burner is switched on (for hybrid systems).

✓ The selected minimum buffer tank temperature will appear in the display.

MINIMUM BOILER  
TEMPERATURE

18. Confirm using the *Arrow* button.

- ✓ The minimum buffer tank temperature is set and the menu will advance to the next setting.
- ✓ The message “**Min. boiler TK<sub>min</sub>** [°C] 60” appears in the display.



The “minimum boiler temperature” should not be set to less than 60°C.



19. Use the *Plus* or *Minus* button to select the required “minimum boiler temperature”.

- ✓ The selected temperature will appear in the display.



20. Confirm using the *Arrow* button.

The setting is stored and the menu will advance to the next setting.

MINIMUM FLUE GAS  
TEMPERATURE

- ✓ The message “**Min. flue gas temp. / TA<sub>min</sub>** [°C] 100” appears in the display.



This value is the required lowest temperature setting for the chimney. Observe the specifications provided by the chimney designer and the chimney manufacturer.



21. Use the *Plus* or *Minus* button to select the appropriate minimum flue gas temperature.

- ✓ The selected temperature will appear in the display.



22. Confirm the minimum flue gas temperature setting with the *Arrow* button.

- ✓ The minimum flue gas temperature is set and the menu will advance to the next setting.

## RETURN VALVE RUNTIME

- ✓ The message “**Return valve [sec.] 150**” appears in the display.



23. Use the *Plus* or *Minus* button to select the runtime for the installed servo drive for the return valve.



Please note!

Setting range 120 - 240 seconds.

- ✓ The selected runtime will appear in the display.



24. Confirm using the *Arrow* button.

- ✓ The runtime is set and the menu will advance to the next setting.

## LOADING VALVE RUNTIME

- ✓ The message “**Loading valve [sec.] 150**” appears in the display.



25. Use the *Plus* or *Minus* button to select the runtime for the installed servo drive for the loading valve.

- ✓ The selected runtime will appear in the display.



Please note!

Setting range 120 - 240 seconds.



26. Confirm using the *Arrow* button.

✓ The basic settings have been set. The display will revert back to the standard display mode, which alternately indicates the operating status and the boiler temperature.

### SETTING THE TARGET BOILER TEMPERATURE



1. Press the *Arrow* button.

✓ **SELECTION** and **INFORMATION** will appear in the display.



2. Press the *Plus* button.

✓ **SELECTION** and **SETTINGS** will appear in the display.



3. Press the *Arrow* button.

✓ **Target boiler temperature TK S [°C]** will appear in the display.



4. Use the *Arrow* button to select parameters.

✓ The value will flash in the display.



5. Use the *Plus* or *Minus* button to increase or decrease the value (factory default 80°C).



Please note!

Adjustable range **80°C to 84°C**. **HDG recommendation: 82°C**.



6. Confirm the input value with the *Arrow* button.

✓ The boiler target temperature is set.

See section “4.3 Structure of the menus” in chapter “4 Using the HDG Euro”.

✓ The control system HDG Lambda Control 1 has been set-up for your system and is ready for operation.

7. Record the data and set values in the following table so that the parameters are readily available in case service is needed.



### CUSTOMER DATA

Customer data	
Customer's name	
House Street	
City	
Postal code	
Telephone	
Boiler type	HDG Euro V 3.0 kW
Boiler number	

Table 7/1 - Customer data

### MEMORANDUM FOR SET VALUES

Setting description	Standard configuration	Alternative settings
Language	• GB	
Hydraulic system (electrical connection)	• 0	
Accumulator sensor	• Yes	
Accumulator sensor length in [m]	• 8 m	
Minimum buffer tank temperature $TS_{min}$ [°C]	• 45 °C	
Minimum boiler temperature $TK_{min}$ [°C]	• 60 °C	
Minimum flue gas temperature $TA_{min}$ [°C]	• 100 °C	
Return valve runtime [sec]	• 150 sec.	
Loading valve runtime [sec]	• 150 sec.	

Table 7/2 - Set values

## TESTING SYSTEM COMPONENTS

**Caution!**

For safety reasons, the system component test may only be conducted when there is no fuel in the boiler and there are no remaining embers.



Please note!

Test can only be conducted in **"Heat production off"** mode.

## HOW TO PROCEED



The test of the respective component is started by pressing the *Plus* button.



The test is stopped by pressing the *Minus* button.



The test is conducted on the next component by pressing the *Arrow* button.



The component test is stopped by simultaneously pressing the *Plus* and *Minus* buttons.



1. Press the *Arrow* button.

✓ The message **"Selection/information"** appears in the display.



2. Press the *Plus* button.

✓ The display changes to **Selection/settings**.



3. Press the *Plus* button again.

✓ The display changes to **Selection/component test**.



4. Press the *Arrow* button.

✓ The message **"O2 sensor test"** appears in the display.



5. Press the *Plus* button.

✓ The O2 sensor test will begin. **(Duration = 720 seconds)**

 See the paragraph "Calibrating the lambda sensor", section "5.2 How to proceed", chapter "5 Cleaning and maintaining the HDG Euro".

✓ The O2 sensor test is completed.



6. Press the *Arrow* button.

✓ The display advances to the next component: **primary pump**.

7. Conduct the test according to steps listed above for each individual component in the order listed below.

The component testing sequence is as follows.

- Return valve (Y1)  
The switch (1) of the servo motor has to be moved in the position as shown in figure 7/1.

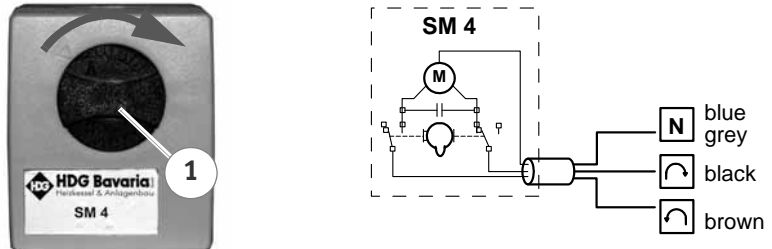

Figure 7/1 - Switch servo motor

To change the direction of rotation the black and the brown wire at the servo motor have to be swapped.  
The closed door (1) is shown by groove (2) at the axle of the return Valve Y1.

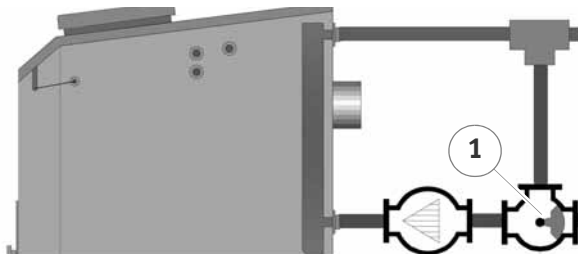

Figure 7/2 - Return valve Y1

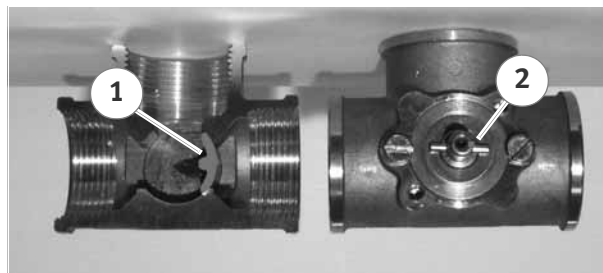

Figure 7/3 - Return valve Y1

The switch (1) of the servo motor has to be moved in the position as shown in figure 7/4.



Figure 7/4 - Switch servo motor

The closed door (1) is shown by groove (2) at the axle of the return Valve Y 1.

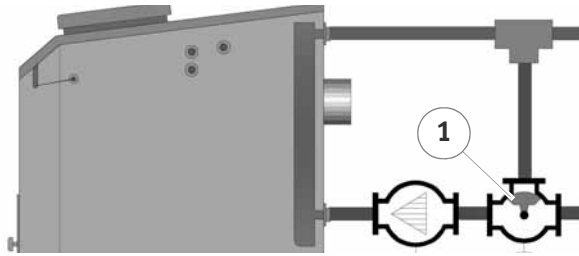

Figure 7/5 - Return valve Y1

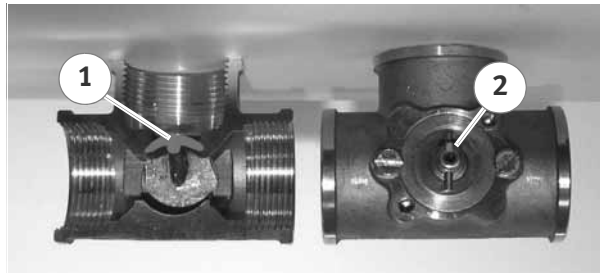

Figure 7/6 - Return valve Y1

- Fan
  - Door opener (not fitted on HDG Euro V3.0 with HDG Lambda Control 1)
  - Primary (air) actuator motor
  - Secondary (air) actuator motor
  - Charging valve (Y2)
- 📎 See testing sequences „Return valve (Y 1)“ one page before.
- Change-over contact
  - Illumination (display)
  - Heat production on LED
  - Reload LED
  - Fault LED



After the last component has been tested, the display will automatically switch the control system HDG Lambda Control 1 to **“Heat production off”** mode.

**The HDG Lambda Control 1 system does not require any additional settings.**

✓ The component test is completed.

### SETTING THE PRIMARY AIR GUIDE AND THE GRATE HEIGHT FOR THE RESPECTIVE FUEL

An optimum gasifying of the fuel and thus an efficient combustion can only be achieved if the boiler is preset for the fuel to be used and its burning properties. Adapting to the on-site conditions is also of critical importance.

**i**

Every switch of fuel type, e.g. from softwood to hardwood, requires a resetting of the boiler to the changed requirements of the fuel!

This adjustment is only to be performed by trained personnel.

#### FACTORY PRESETTINGS

Control element	Input
Air slit on air adjuster plate (threshold of upper ash door)	<ul style="list-style-type: none"> <li>• 3 mm</li> </ul>
Air damper on cleaning flap	<ul style="list-style-type: none"> <li>• closed above</li> <li>• open halfway below</li> </ul>
Grate	<ul style="list-style-type: none"> <li>• raised 25 mm</li> </ul>

Table 7/3 - Presetting the inputs

#### SETTING THE PRIMARY AIR GUIDE

1. Open the ash door (3).

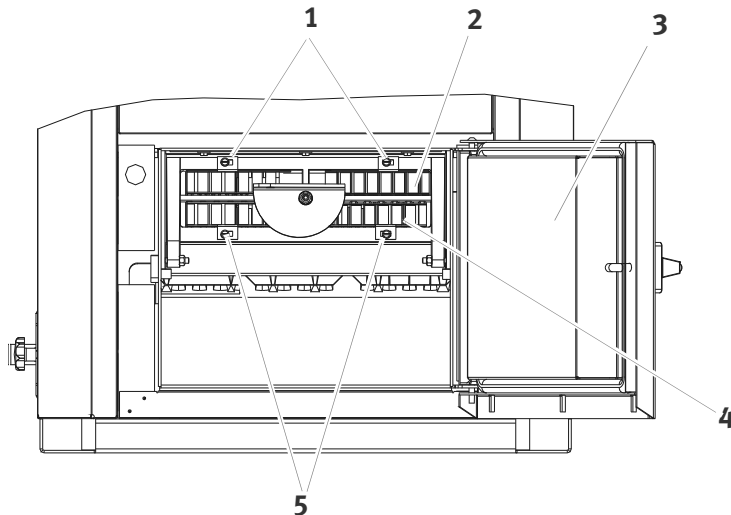

Figure 7/7 - Boiler presetting

2. Release the retaining screws (1 + 5) with a screwdriver.
  3. Open the air damper (4 + 2) on the cleaning flap according to the specifications in Table 7/3 - Presetting the inputs.
  4. Tighten the retaining screws (1 + 5).
- ✓ The primary air guide is now set.

## GRATE LIFTER



In the HDG Euro V3.0 with HDG Lambda Control 1 for log wood, the grate lifter is already installed in a horizontal position!

The position of the grate lifter (2) can be changed in order to correct the gas quantity during degassing and thus avoid pulsating (sudden igniting due to lack of oxygen) or insufficient flue gas temperatures. This is only required for greater deviations from the recommended fuel or for deviations from the required temperatures for safe operation of the log wood boiler.

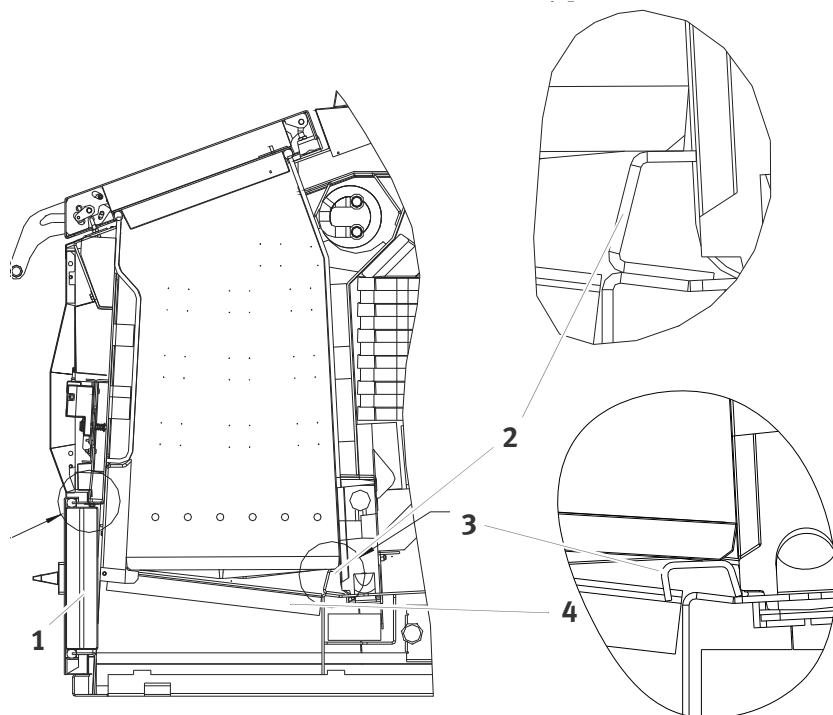

Figure 7/8 - Boiler presetting

1. Open the front ash door (1).
2. Take the flat grate element (4) out toward the front.
- ✓ The grate lifting bar can be seen in Figure 7/8 - Boiler presetting as designated with number (3).
3. Set the grate lifting bar (2) as shown in Figure 7/8 - Boiler presetting.
4. Insert the flat grate element (4).
- ✓ The grate height is now set.
5. Heat the log wood boiler as described in chapter “4 Using the HDG Euro”, section “4.6 Lighting and reloading the HDG Euro”.

# 8 Notes on dismantling and disposal

## 8.1 Dismantling



### Danger!

Material damage and injury due to incorrect dismantling.

Only dismantle the boiler after you have thoroughly read the manual.

The HDG Euro can be dismantled as follows.

1. Allow the fire in the HDG Euro to burn out and for the system to cool off.



### Danger!

Danger from electrical current or voltage

The HDG Euro can only be completely de-energised by switching off the mains circuit breaker or the emergency heating switch.

2. Switch off the HDG Euro at the emergency heating switch or the mains circuit breaker.

 See section “4.7 Switching off the HDG Euro for maintenance or repair work” in chapter “4 Using the HDG Euro”.

✓ The system has been de-energised.

✓ The control is deactivated.

3. Disconnect the HDG Euro from the electrical power supply.



### Caution!

Danger of burns from hot surfaces and liquids.

When operating, the boiler surfaces under the cladding are hot. Even when turned off, they only cool down slowly.

Switch off the HDG Euro, and only begin dismantling it after it has cooled down.

4. Once it has cooled down, drain the heating water from the system.
5. Observe personal safety regulations when disconnecting the boiler from the HDG Euro.



**Caution!**

Hand injuries

Some of the combustion chamber components are very heavy and can cause injuries if they are not handled with care.

6. Dismantle the individual components of the HDG Euro.

✓ The combustion chamber is dismantled.

## 8.2 Disposal

The following components are made of steel and can be recycled via a local recycling centre.

- Boiler
- Cladding

The electrical components can also be recycled via the local recycling centre.

Fibreglass, mineral wool and plastic parts should be brought to the relevant waste disposal centres.



Oily or greasy components and condensers may only be disposed of through a specialist waste disposal centre.

# 9 Warranty and extended warranty

## 9.1 Specification

For the boiler body, we have extended the compulsory warranty period from two to five years.

For electrical and other components, the warranty period is two years.

## 9.2 Extended warranty conditions

In addition to any legal stipulations, the following legal requirements must also be met for all warranty claims:

- The HDG Euro must be commissioned by our customer service department or by an authorised specialist company.
- The HDG Euro must be operated as specified in the operating manual.
- The installation of the HDG Euro and the hydraulic components must meet the requirements in the HDG planning and installation instructions and the specified HDG hydraulic diagrams.
- The HDG Euro must be installed according to applicable rules, regulations and guidelines.
- The fuel quality must correspond to the requirements specified by HDG Bavaria GmbH.
- The apparent defect is to be remedied by HDG Bavaria GmbH.

## 9.3 Warranty exclusions

Unauthorised modifications and damage due to excessive force are not covered by the warranty.

The warranty does not cover:

- Damage due to improper use or installation, nor damage caused by inadequate maintenance or by the operation of the system and the HDG Euro in an impermissible way.
- Damage caused by external influences (such as fire, water, lightning, excess voltage) and normal wear and tear (e.g. of seals, etc).
- Corrosion damage, which is caused by operating the system below the minimum nominal thermal output level specified by the manufacturer.
- Corrosion damage, which results from the use of non-approved fuels.
- Corrosion damage, which is caused by operating the system below the specified minimum boiler return temperature.
- Damages caused by subjecting the boiler sheeting to extreme heat, as the result of boiler blockages on the water side.

# 10 Declaration of conformity

## EC declaration of conformity

### in accordance with the EC directive machinery 98/37/EC, annex II A

as well 2006/95/EC Directive 2006/95/EC of the European Parliament and of the Council of 12 December  
 as: 2006 on the harmonisation of the laws of Member States relating to electrical equipment designed  
 for use within certain voltage limits (codified version) (1)  
 89/336/EEC Council Directive 89/336/EEC of 3 May 1989 on the approximation of the laws of the  
 Member States relating to electromagnetic compatibility  
 97/23/EC Directive 97/23/EC of the European Parliament and of the Council of 29 May 1997 on the  
 approximation of the laws of the Member States concerning pressure equipment

#### The construction of the machinery

Make: HDG Euro V3.0  
 Type: HDG Euro 30V3.0 /40V3.0 /50V3.0

has been developed, designed and manufactured in accordance with the EC directive/s as above, in the sole  
 responsibility of

Company: HDG Bavaria GmbH, Heizsysteme für Holz  
 Siemensstraße 22  
 D-84323 Massing

#### The following harmonized and national standards and specifications have been applied:

EN 303-5 : 1998.11.12	Part 5: Heating boilers for solid fuels, hand and automatically stocked, nominal heat output of up to 300 kW Terminology, requirements, testing and marking
EN 1050 : 1996-11	Safety of machinery - Principles for risk assessment
EN ISO 12100-1 : 2003-11	Safety of machinery - Basic concepts, general principles for design - Part 1: Basic terminology, methodology
EN ISO 12100-2 : 2003-11	Safety of machinery - Basic concepts, general principles for design - Part 2: Technical principles
EN 60204-1 : 1997-12	Safety of machinery - Electrical equipment of machines - Part 1: General requirements
EN 60335-1 : 2002-10	Household and similar electrical appliances - Safety - Part 1: General requirements

Massing, 04.06.2008

Place, date



Signature  
 Wohlmannstetter  
 Geschäftsführer

**HDG Bavaria GmbH**

Heizsysteme für Holz  
Siemensstraße 22  
D-84323 Massing  
Tel. +49(0)8724/ 897-0  
info@hdg-bavaria.com  
www.hdg-bavaria.com