

This Manual Must Always be Available to the Stove Operator



Euroheat
Natural Energy Company



Installation Instructions

Nestor Martin

C23,C33 **Smoke Control Exempt**

C43

Q13,D33,023,NM33

IN1210 Edition B1 October 2010

PART NUMBER

SERIAL NUMBER

This manual must be used in conjunction with document IN1173. The Wood and Mutlifuel Chimney and Installation Guide.

IMPORTANT

Since April 2002 only Registered Competent Engineers may install solid fuel fired appliances without involving the Local Authority Building Control Department. For more details contact HETAS. Euroheat would suggest only Registered Competent Engineers install Euroheat appliances. If the installer is not a registered Competent Engineer we would advise that property owners insurance company is contacted to confirm their insurance is not affected.

■ The installation of this appliance must comply with all local regulations, including those referring to national and European Standards before it can be operated. The stove is not suitable for a shared flue. However, for England and Wales, only, the coming into force on 1st April 2002 of SI 2002 No 440 exempts the householder from this legal requirement for the installation of solid fuel fired appliance whose rated heat output is 50kW or less in a building having no more than 3 storeys (excluding any basement) if a Competent Engineer is employed who is registered under the Registration Scheme for Companies and Engineers involved in the Installation and Maintenance of Domestic Solid Fuel Fired Equipment operated by HETAS Ltd. These registered Competent Engineers may also carry out associated building work necessary to ensure that the installed appliance complies with Building Regulations without involving the Local Authority Building Control Department.

■ Improper adjustment, alteration, maintenance or the fitting of replacement parts not recommended by the manufacturer can cause injury or property damage. Do not operate the stove with faulty seals or damaged glass.

■ Due to the high operating temperatures of this appliance it should be located away from pedestrian traffic and away from furniture and draperies. Do not store paper or wood near the appliance. Any mats and rugs put in front of the stove should be fire proof and secured to prevent the possibility of tripping.

■ Advise all persons as to the stove's high surface temperatures. If it is possible for children or infirm adults to come into contact with the stove, fit a suitable fire guard.

■ It is imperative that all air passageways into, out of, and within the appliance are kept clean. All permanent ventilation into the room provided for the stove must remain clear and unobstructed at all times. Consideration must be given to the need for extra ventilation if another heating source needing air is to be operated simultaneously. If an extraction fan is proposed to be fitted to a connecting area of the house, after the stove has been installed, professional advice should be sought from a qualified engineer.

■ The user should be advised that the appliance should be inspected regularly and the chimney cleaned at least annually.

More frequent cleaning may be required and the advice of a qualified chimney sweep should be sought.

■ Our range of stoves is capable of operating with outstanding efficiency if the flue system is correct. Because so little heat is wasted to the flue it is possible that moisture within the products of combustion will condense if the heat losses within the flue way are too great and allow the flue gasses to cool. For this reason we recommend that the stove is fitted with a suitable flue liner, the same diameter as the flue spigot, to prevent the possibility of acidic damage to the fabric of the chimney and damage to the stove which will reduce the longevity of the stove.

■ When correctly installed, the stove is designed to produce heat, safely. It cannot do so if the installation is less than absolutely stable, constructed of materials suitable for such an installation and consideration has not been given to the possibility of people with less than ideal common sense operating it.

■ Have the existing chimney swept by a chimney sweep. Although you will be lining the chimney, any deposits left in the chimney will cause problems and may become a fire hazard.

■ Your attention is drawn to the precautions and responsibilities under the Health and Safety at Work Acts, and whatever new legislation being introduced during the life of this document.

The Model Range Explained

Nestor Martin and Euroheat insist on progressive development to produce products which are market leading. Our aims are to produce stoves with the latest innovations, user friendly operation and highly efficient for lower cost operation.

This manual offers installation information for the range of Nestor Martin Q13,C23,C33,C43,D33,O23 and NM33. In some cases you find references in this document to the model size rather than the models exterior design. There are four sizes of appliances, 13, 23, 33, 43. The 13 is the smallest and the 43 the largest. Although the exterior clothes change between model ranges the internal workings are the same.

Model Identification

You will see on the front page of this document a label which confirms which model you have. This label also advises you of the stoves unique serial number. This information is also attached to your stove for reference.

Important

Please ensure the warranty registration form is completed if you are the installer and confirm with the user that it is their responsibility to return it to Euroheat. In this way the model and its history will be recorded for reference in the future.

For the latest versions of manuals, technical information, accessories and spare parts visit the Euroheat web site.



Euroheat
Natural Energy Company

Stoves supplied through Euroheat authorized retailers.

For England, Wales, Scotland and Northern Ireland

Euroheat Distributors (H.B.S). Ltd.
Unit 2, Court Farm Business Park,
Bishops Cleeve,
Worcestershire. WR6 5AY.

www.euroheat.co.uk

info@euroheat.co.uk

Whilst Euroheat are always happy to assist, please ensure you have read this manual and the chimney and installation guide IN1173.

First contact your supplying retailer for assistance. If you find this not successful contact the Euroheat Technical support team. Technical support telephone Number 01885 491117. E-mail tech@euroheat.co.uk.

Before telephoning ensure you have the stoves serial number to hand and that you are a Registered Competent Engineer. If you are not a registered engineer seek one for assistance. A list of engineers can be obtained from HETAS.

Euroheat unfortunately are NOT able to offer support for appliances which were not supplied by Euroheat.



Stoves supplied through Eireheat authorized retailers.

For Eire

Sean Murphy Heating Ltd
Kinvara
Co Galway
Eire

www.eireheat.com

sales@eireheat.com

(091)637701 Fax: (091)637797
International +353 91637701

For support for appliances supplied through Eireheat in Ireland please contact using the details listed above.

**NESTOR
MARTIN**

Thermic Distribution Europe Sa
11 Rue De Lion
B-5660
Frasnes Les Couvin, Belgium.

www.nestormartin.com

Technical Details Intermittent Operation

Intermittent operation is when the appliance is used for short firing periods for example 45 minutes to 2 hours. This is a common operation in warmer weather such as cold spring evenings. The information provided below where indicated as HETAS approved is from the current CE standards EN 13240:2001 and EN 13240 A2:2004. The test fuel for wood burning, beech, for coal burning anthracite.

Model Name	Model Number	Heat Output Nominal Wood	Heat Output Nominal Coal	Weight KG	Flue Draught Nominal	Flue Gas Mass Flow g/s	Flue Gas Temperature Down Stream of Flue Spigot deg C	Efficiency with Top Flue Connection
Nestor Martin Q13 Wood	Q13	4.6kW		74	12pa	4.9	293	77.1% Net 70.2% Gross
Nestor Martin Q13 Coal	Q13		3.6kW	74	12pa	3.8	210	82.8% Net 75.4% Gross
Nestor Martin C23	C23	7.7kW	7.7kW	180	12pa	7.7	326	77.2% Net 70.0% Gross
Nestor Martin C33	C33	9.2kW	9.2kW	185	12pa	6.5	357	80.0% Net 72.8% Gross
Nestor Martin C43	C43	10.5kW	10.5kW	224	12pa	6.5	357	79.7% Net 72.5% Gross
Nestor Martin O23	O23	7.6kW	6.1kW	104	12pa	7.7	326	77.2% Net 70.0% Gross
Nestor Martin D33	D33	9.0Kw	8.4kW	108	12pa	6.5	357	80.0% Net 72.8% Gross
Nestor Martin NM33	NM33	9.0Kw	8.4kW	200	12pa	6.5	357	80.0% Net 72.8% Gross

Technical Details Continuous Operation

Continuous operation is when the appliance is used for long firing periods for example several hours and for overnight operation. This is a common operation in cold weather as experienced in deep winter. The information provided below is from the current CE standards EN 13240:2001 and EN 13240 A2:2004. The test fuel for wood burning, beech, for coal burning anthracite.

Model Name	Model Number	Heat Output Nominal Wood	Heat Output Nominal Coal*	Weight KG	Flue Draught Nominal	Flue Gas Mass Flow g/s	Flue Gas Temperature Down Stream of Flue Spigot deg C	Efficiency with Top Flue Connection
Nestor Martin Q13 Wood	Q13	5.0kW		74	12pa	4.9	293	83.4% Net 75.9% Gross
Nestor Martin Q13 Coal	Q13		3.5kW	74	12pa	3.8	210	78.3% Net 71.2% Gross

Smoke Control Exempt



Models listed as smoke control exempt have passed the very strict U.K. requirements and can operate in smoke control zones burning dry seasoned wood.

Model	Flue Size	Air Requirement Equivalent Area as Approved Document J >5.0m ³ /(h.m ²)	UK Smoke Control Exemption Burning Wood	Efficiency Net % Rear flue	Efficiency Net % Top flue	Efficiency Gross % Rear flue	Efficiency Gross % Top flue
Nestor Martin NM33	6" (153mm)	2200mm ²		77.6		69.7	
Nestor Martin O23	6" (153mm)	1430mm ²		70	70	77	77
Nestor Martin C23	6" (153mm)	1485mm ²	Approved	70	70	77	77
Nestor Martin C33	6" (153mm)	2310mm ²	Approved	80		72.8	
Nestor Martin C43	7" (180mm)	3025mm ²		80		72.8	
Nestor Martin D33	6" (153mm)	2200mm ²		77.6		69.7	
Nestor Martin Q13	5" (125mm)	Nil*		See intermittent or continuous operation			

* Air requirement equivalent area. Building regulations Document J, advises that an air supply should be installed for appliances with a heating output over 5kW. Document J indicates that there should be sufficient advantageous air for heating outputs below this amount. With modern properties this may not always be the case and/or more free air may be required. Continuous or intermittent operation will result in different heating outputs due to the nature of the fuel and the appliance. If in doubt increase the suggested area listed or contact your HETAS approved engineer for assistance.

* Free Air Requirement

Air requirement equivalent area. Building regulations Document J, advises that an air supply, permanently open vents, should be installed for appliances:

If design air permeability >5.0m³/(h.m²) then 550mm²/kW of appliance rated output above 5kW
or

If design air permeability ≤5.0m³/(h.m²) then 550mm²/kW of appliance rated output

Equivalent air is as measured according to the method in BS EN13141-1:2004

It is unlikely that a dwelling constructed prior to 2008 will have an air permeability of <5.0m³/(h.m²) at 50pa unless extensive measures have been taken to improve air-tightness.

Carbon Monoxide Alarms

Where a new solid fuel stove is installed in a property a carbon monoxide alarm should be located in the same room where the appliance is located:

- on the ceiling at least 300mm from any wall or, if it is located on a wall, as high up as possible (above any doors and windows) but not within 150mm of the ceiling; and
- between 1m and 3m horizontally from the appliance.

Carbon monoxide alarms should comply with BS EN 50291:2001 and be powered by a battery designed to operate for the working life of the alarm. The alarm should incorporate a warning device to alert users when the working life of the alarm is due to end. Mains-powered BS EN 50291 Type A carbon monoxide alarms with fixed wiring (not plug in types) may be used as alternative applications provided they are fitted with a sensor failure warning device.

Useful Organizations UK

Solid Fuel Association

0845 601 4406

www.solidfuel.co.uk

The National Association of Chimney Sweeps

01785 811732

www.chimneyworks.co.uk

HETAS Ltd.

0845 634 5626

www.hetas.co.uk

Stoves Construction

The plexus control is the centre of the air inlet system. The fuel selection controls direct the air flow, either air wash or under grate. The burning rate controlled by the amount the fuel selection controls are adjusted.

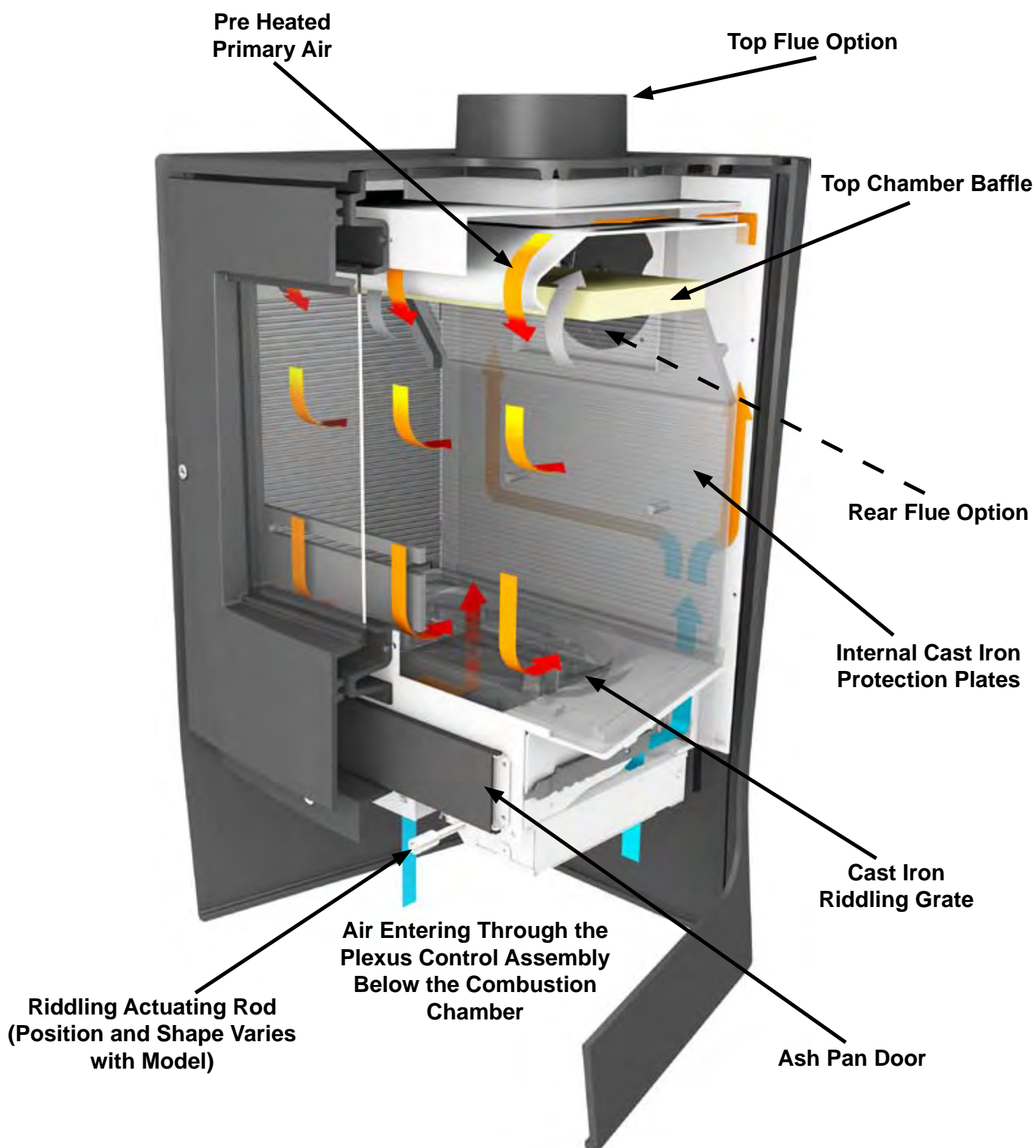

Q13: Correct Position of the Flue Baffle Plate in the Flue Baffle

The Q13 has a flue baffle fixed to the top of the stove below the flue outlet. Its function is to direct the flue gases around the whole top of the stove so speeding up the time the combustion chamber heats up on this model. This baffle can be removed to access the flue for sweeping.

Ensure that the baffle plate is in the correct position when commissioning the stove.

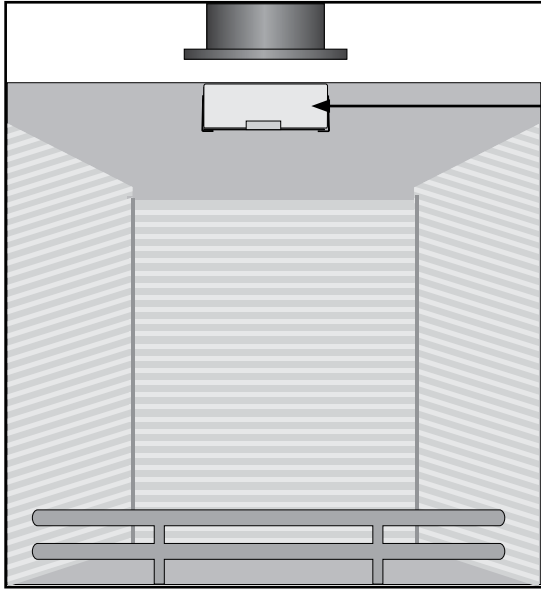

The flue baffle is fixed to the top of the stove below the flue outlet.

Lift the flue baffle plate up to the flue baffle. The wing towards the back of the stove and with it angled downwards. The lugs on the flue baffle plate should be located in the cut out on the base of the flue baffle.

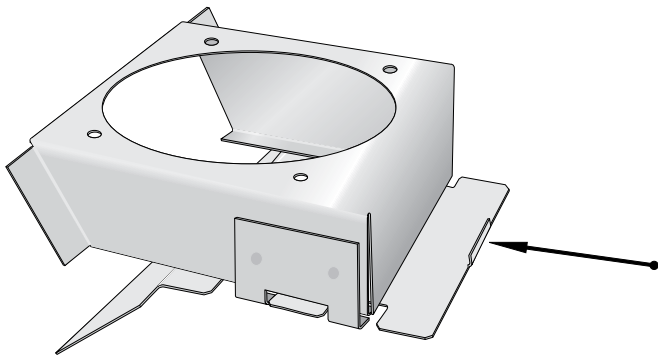
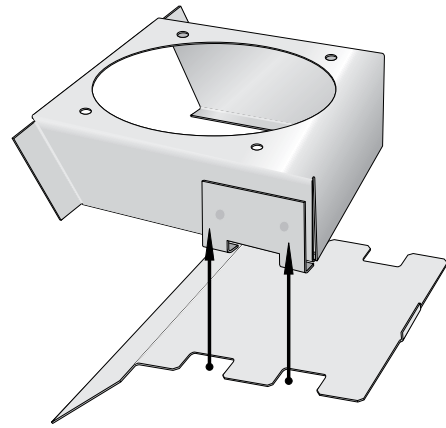

Once the lugs have been located into the cut out on the base of the flue baffle slide it towards the back of the stove until it is fully pushed in.

The baffle plate is in the correct position when the small upturn on the baffle plate is against the facing wall of the flue baffle.

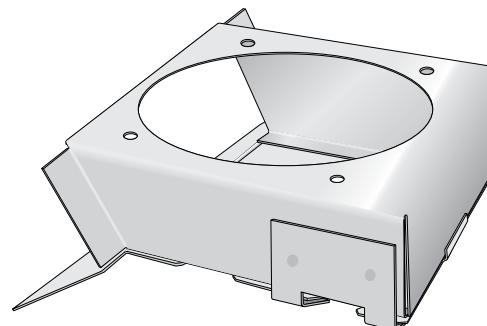

Q13: Changing to Rear Flue Connection

1. Remove flue spigot and spigot protection from the top of stove.
2. Some models will require the rear heat shield rear flue access plate to be removed. With a hacksaw blade or screwdriver remove the section from the rear heat shield which covers the rear flue outlet.
3. Remove the flue blanking plate from rear of stove.
4. Fit the blanking plate to the top of stove with the blanking plate protector underneath (see below).
5. Fit the flue spigot to rear of stove (do not fit spigot protector).

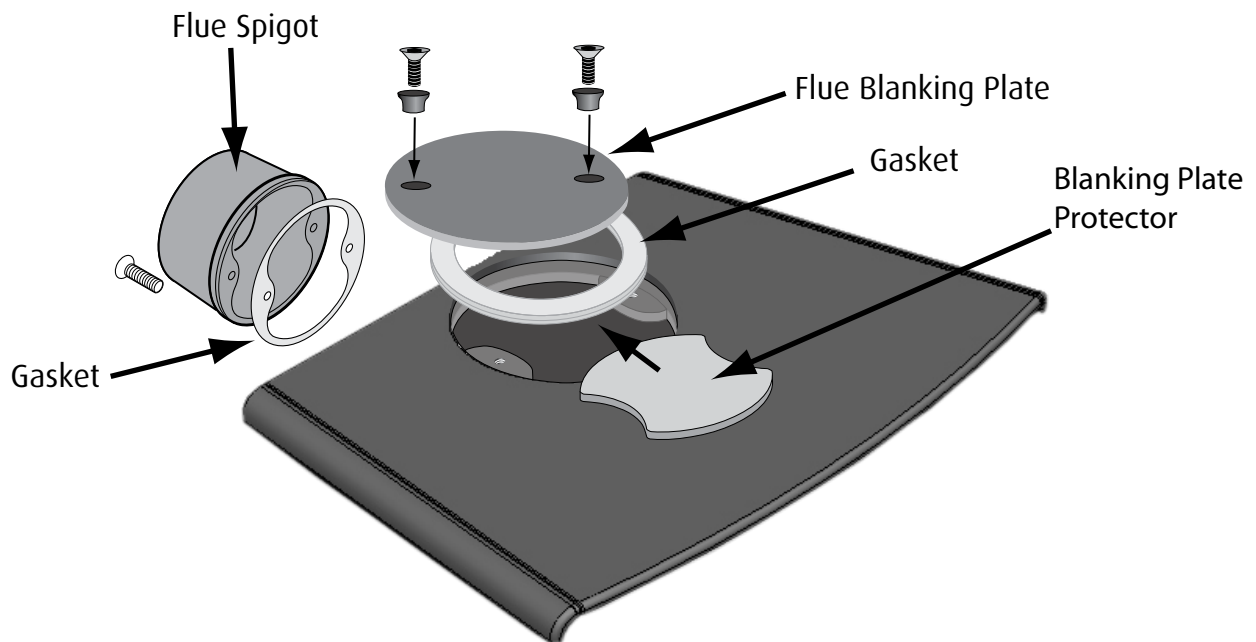

Top Flue Blanking Plate Protector Location

The blanking plate protector fits into the top of the combustion chamber below the top flue blanking plate. This cast iron plate, see the picture below, may vary in shape. It must be placed into the top outlet of the combustion chamber so it sits level blanking off this outlet. The top flue blanking plate is then fitted above it using the circular gasket.

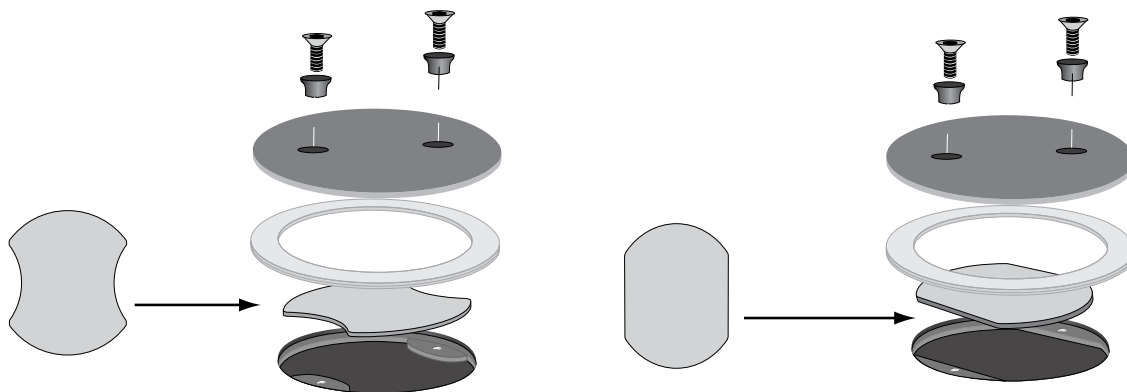

Changing to Top Flue Connection

The procedure is as if fitting the rear flue but follow the information in reverse and fit the flue spigot protector.
(See page 8)

C23,C33,D33,023,NM33: Top Flue Connection

When using top flue outlet the flue spigot should be fitted with the flue spigot protector collar. This protection collar prevents damage to the top flue outlet.

If the flue spigot is fitted to the pallet on which the stove is transported, the spigot protector collar will be found within the stove. You **MUST** ensure that these are correctly fitted, see below, when the top flue option is used. The spigot protector collar is not required if the stove is to be a rear exit flue.

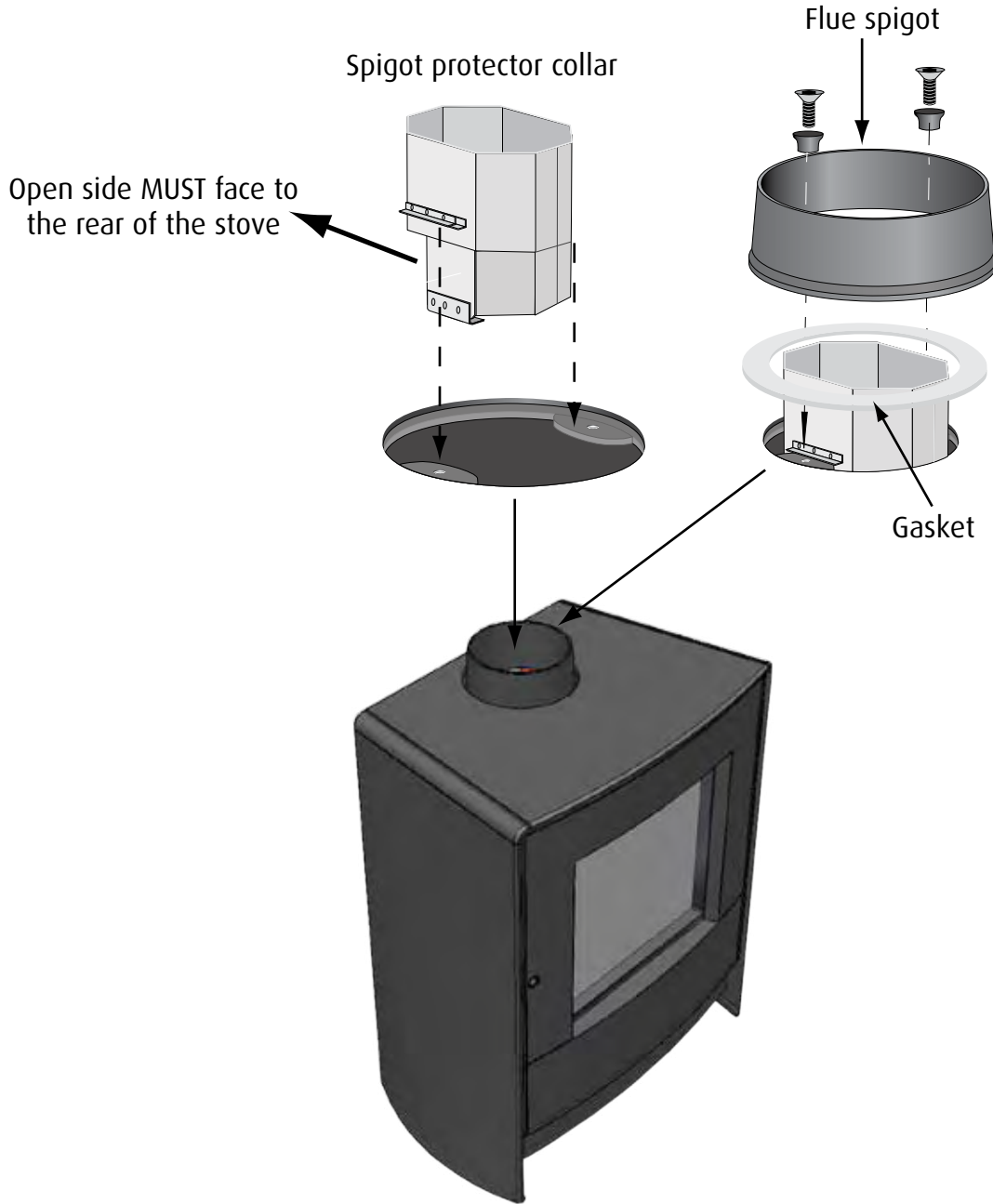

Do not fit flue spigot protector collar for rear outlet option.



C23,C33,D33,023,NM33: Top Flue Winged Baffle Location

When using the top flue outlet certain models use a flue spigot protector. This protection tube prevents damage to the flue outlet collar if enamelled and the winged baffle plate which fits at its base slows down the movement of flue gasses to the flue system.

It is important that this winged baffle plate is fitted correctly, as if fitted incorrectly will lead to difficulties in its removal when accessing the flue system for cleaning.

It should be slid into the spigot protector with the wing pointing downwards and the small up stand at the other end upwards. It should be slid all the way into the protector until the small up stand touches the face of the protector.



Slides into the flue spigot protector, the wing downwards, towards the back of the stove

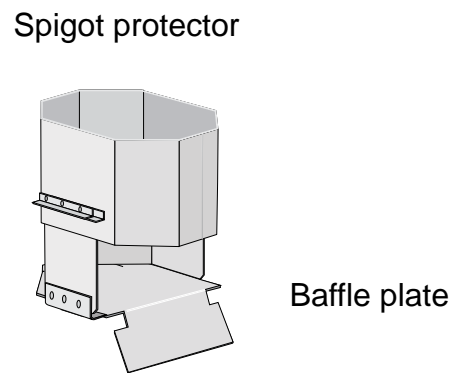
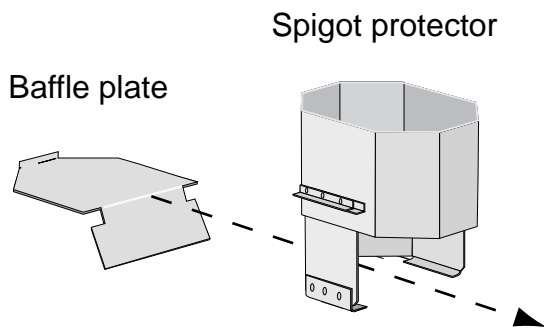

C23,C33,C43: Changing to Rear Flue Connection

Remove the top plate from the stove and turn it over so exposing the two screw holes to which the blanking plate bracket is attached. Using the screws supplied in the bag of installation accessories fit the bracket as shown below. The circular blanking plate will then rest in the hole, the two holes will correspond to the two lugs on the underside of the blanking plate.

Circular Cast Iron Blanking Plate



Blanking Plate Support Bracket and Screws

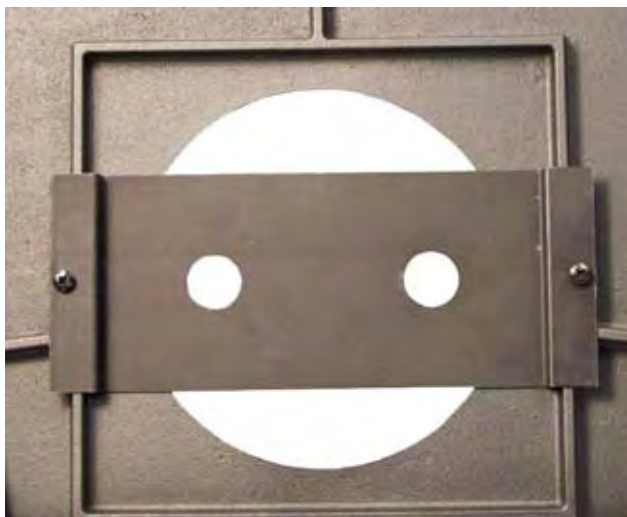

Blanking Plate Support Bracket Fitted to Underside of Cast Top Plate

Remove the rear panel from the stove giving access to the rear flue outlet. The rear panel has a knock out plate which corresponds with the rear flue outlet. This can be removed by cutting the tags with a hacksaw blade or twisting with a screwdriver.

Remove the rear flue blanking plate from the rear outlet and using the ceramic gasket, supplied in the bag of installation accessories, fit this to the top flue outlet so blanking it off.

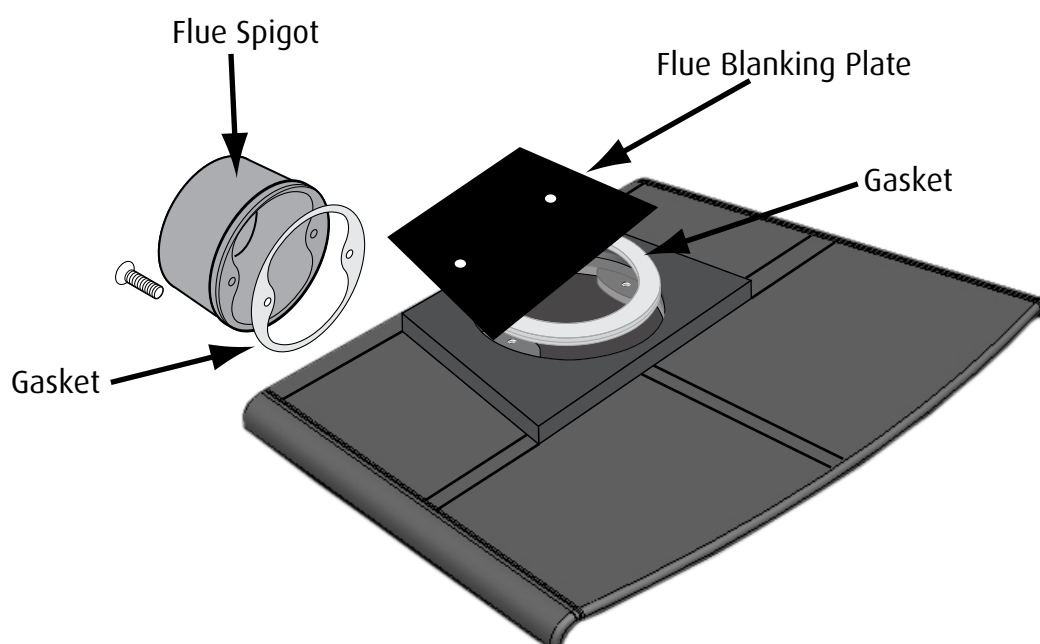

Fit the flue spigot to the rear of the stove using the ceramic gasket which was used for the rear blanking plate.

DO NOT FIT THE SPIGOT PROTECTOR COLLAR WHEN USING THE REAR FLUE OUTLET

Refit the rear panel and top plate to the stove placing the top flue outer blanking plate in the hole in the top plate so it rests on the blanking plate support plate.

D33,023: Changing to Rear Flue Connection

Remove the rear panel from the stove giving access to the rear flue outlet. The rear panel has a knock out plate which corresponds with the rear flue outlet. This can be removed by cutting the tags with a hacksaw blade or twisting with a screwdriver.

Remove the rear flue blanking plate from the rear outlet and using the ceramic gasket, supplied in the bag of installation accessories, fit this to the top flue outlet so blanking it off. The blanking plate and gasket should be slid from the back, between the top of the stove and the combustion chamber beneath, and then secured with the screws supplied. The top steel blanking plate can then be fitted into the top flue outlet, where it just rests on the the inner rim of the hole.

The flue spigot can then be attached to the rear outlet using the ceramic gasket and screws supplied and the rear panel fitted back to the stove.



DO NOT FIT THE SPIGOT PROTECTOR COLLAR WHEN USING THE REAR FLUE OUTLET

NM33: Changing to Rear Flue Connection

Remove the rear panel from the stove giving access to the rear flue outlet. The rear panel has a blanking plate which corresponds with the rear flue outlet, this plate is fixed to the rear panel by screws and a bar. Remove the blanking plate from the rear panel and take off the support bar, this will not be needed to attach the blanking plate to the top flue outlet.



Rear flue blanking plate and support bracket



Circular Blanking Plate

Remove the top plate from the stove and turn it over so exposing the two screw holes to which the blanking plate bracket is attached. Using the screws supplied in the bag of installation accessories fit the bracket as shown. The circular blanking plate will then rest in the hole the two holes will correspond to the two lugs on the underside of the blanking plate.



Blanking Plate Support Bracket and Screws



The flue spigot can then be attached to the rear outlet using the ceramic gasket and screws supplied and the rear panel fitted back to the stove.

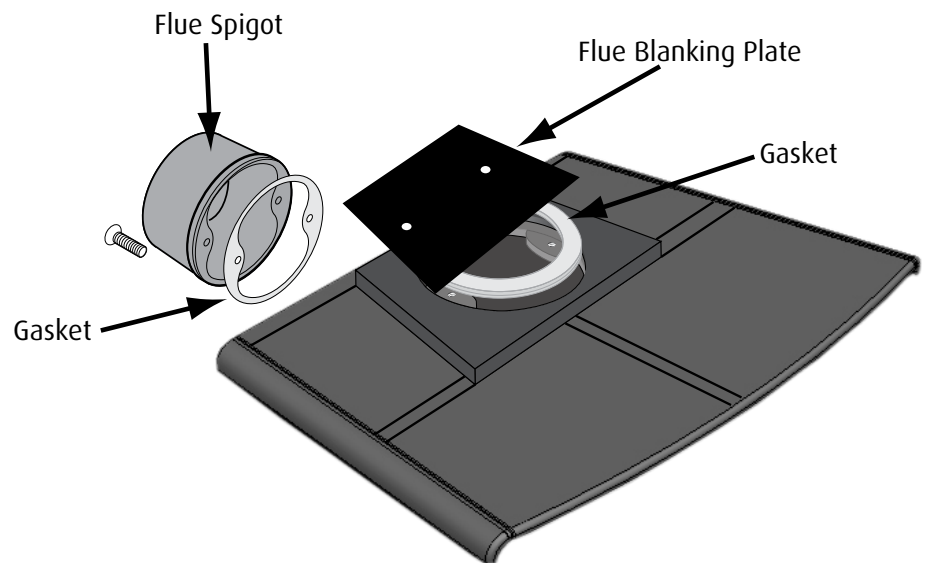

DO NOT FIT THE SPIGOT PROTECTOR COLLAR WHEN USING THE REAR FLUE OUTLET



Fireplace Design

Do not be tempted to fit the stove into an unsuitable fireplace. Beyond the requirements of Building Regulations and access to facilitate servicing the stove, providing a setting which will complement a stove is not a luxury, it is the practicality of making the most of an investment. A good builder or fireplace specialist will be able to transform even the most utilitarian of fireplaces. Whether altering its proportions to those of the "Golden Mean" ideal, see below, or exposing a wooden or stone lintel or simply removing superfluous detailing for a comparatively small cost, and the result will be a pleasure for many years.

"Golden Mean"

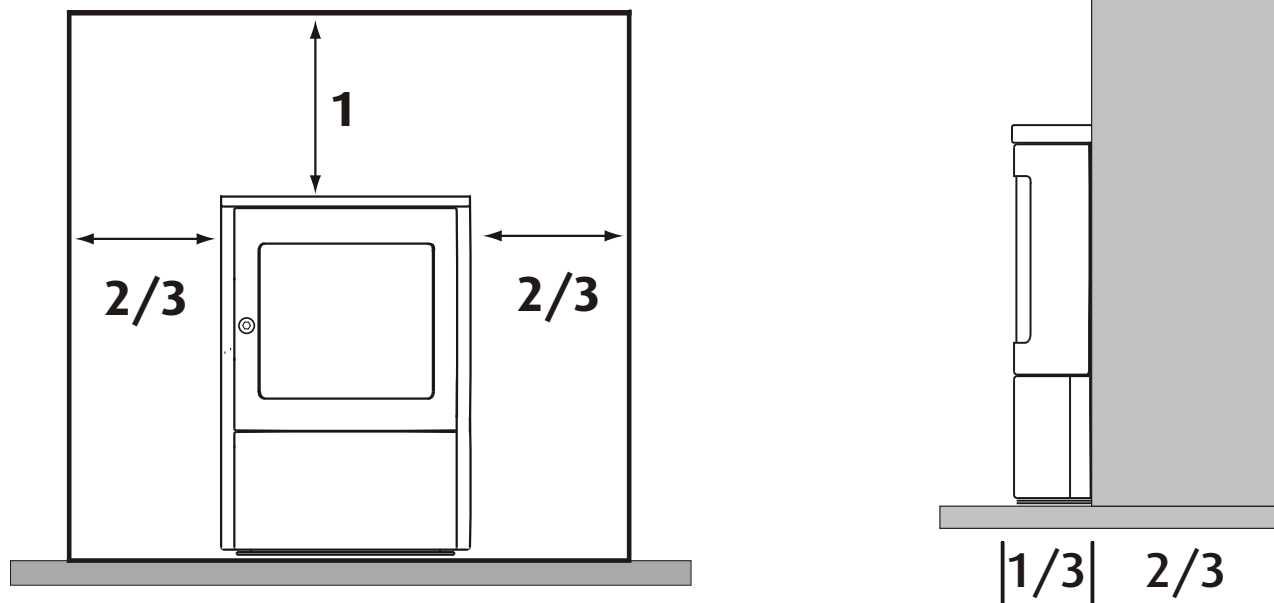

1. The stove must always stand perfectly level. Adjustment screws and/or triangular plastic levelling spacers may be provided with the stove. The provision of a suitable level hearth within the recess is an important consideration when planning a fireplace.
2. Sufficient space should be allowed for service work.
3. At least the minimum clearance from inflammable materials and conforming to the current Building Regulations.
4. Sufficient space around the stove so that the controls may be operated without the risk of injury to the operator and to allow access for servicing the appliance.
5. Mounting brackets should be installed to facilitate the secure fitting of a fire guard, if one is to be fitted to protect the young, elderly or infirm.
6. Curtains and soft furnishings should be a minimum of 1m from the stoves body or the surface temperature of these furnishings must not exceed 65°C.
7. The mounting of expensive paintings, mirrors and plasma screen televisions above a fireplace is not recommended.

Hearths

The stove should stand wholly above a hearth constructed of suitably robust materials and should be able to accommodate the weight of the appliance and its unsupported flue components. The materials should conform to local Building Regulations and British Standards.

If the stove is not to stand in a purpose built fireplace recess (this excludes prefabricated constructions) a hearth made of non-combustible board, steel material, tiles or glass of at least 12mm thick may be used as long as the floor can accommodate the weight of the appliance and its unsupported flue components.

All our multifuel stoves conform to standards where the hearth temperature does not exceed 100°C. This means a hearth of only 12mm of non combustible material can be used. This information only applies to our range of appliances. **Caution** do not fit a 12mm hearth to other manufacturers products unless documentation is provided to prove hearth temperatures.

Minimum Installation Clearances

From Combustible Materials.

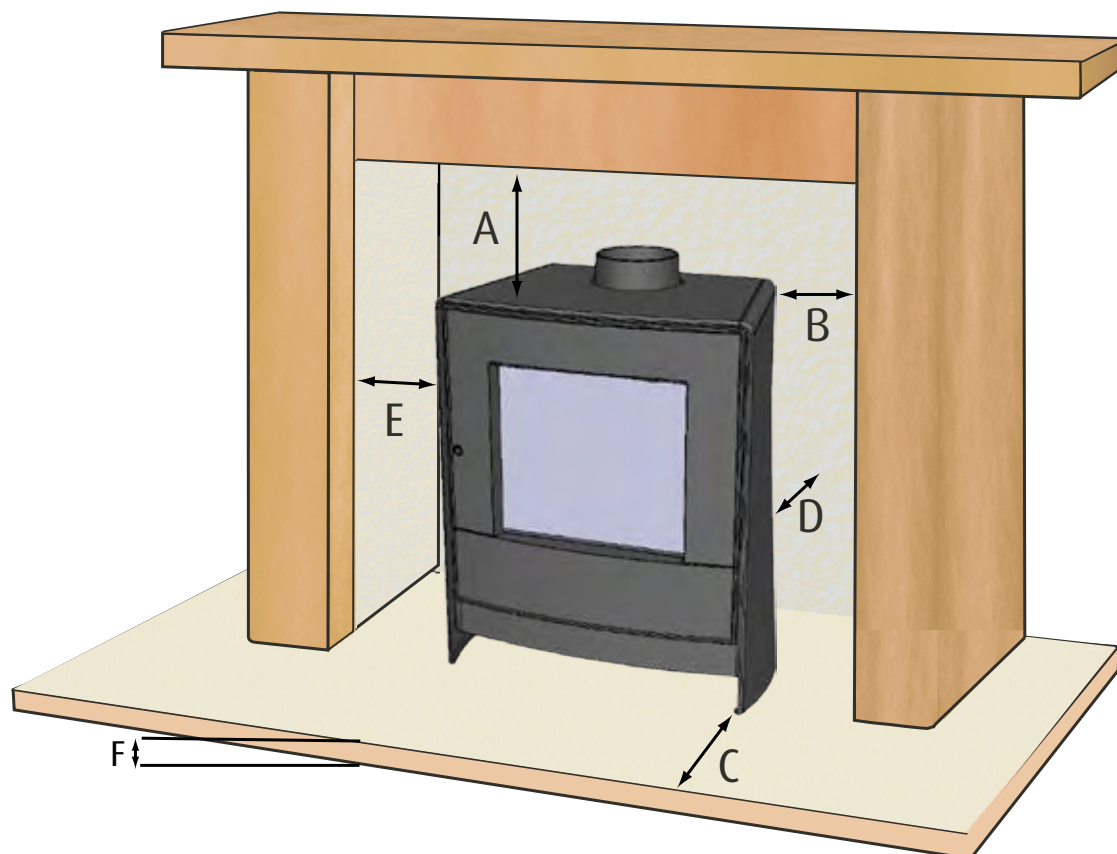

Minimum clearances from combustible materials						
Model	A	B	C	D	E	F*
Nestor Martin Q13 Wood	300mm	150mm	300mm	200mm	150mm	12mm
Nestor Martin Q13 Multifuel	300mm	150mm	300mm	200mm	150mm	12mm
Nestor Martin C23 Wood	300mm	250mm	300mm	300mm	250mm	12mm
Nestor Martin C33 Wood	300mm	250mm	300mm	300mm	250mm	12mm
Nestor Martin C43 Wood	300mm	250mm	300mm	300mm	250mm	12mm
Nestor Martin D33 Wood	300mm	250mm	300mm	300mm	250mm	12mm
Nestor Martin NM33 Wood	300mm	250mm	300mm	300mm	250mm	12mm
Nestor Martin O23 Wood	300mm	250mm	300mm	300mm	250mm	12mm

* When installed as a free standing appliance or in a prefabricated fireplace. All other applications must conform to current constructional fireplace requirements per Building Regulations with a Constructional Hearth.

In all installations surrounding flammable materials must not exceed 65°C.

Curtains and furnishings should be a minimum of 1m from the stove or the surface temperature must not exceed 65°C.

Minimum Installation Clearances

From Non-Combustible Materials.

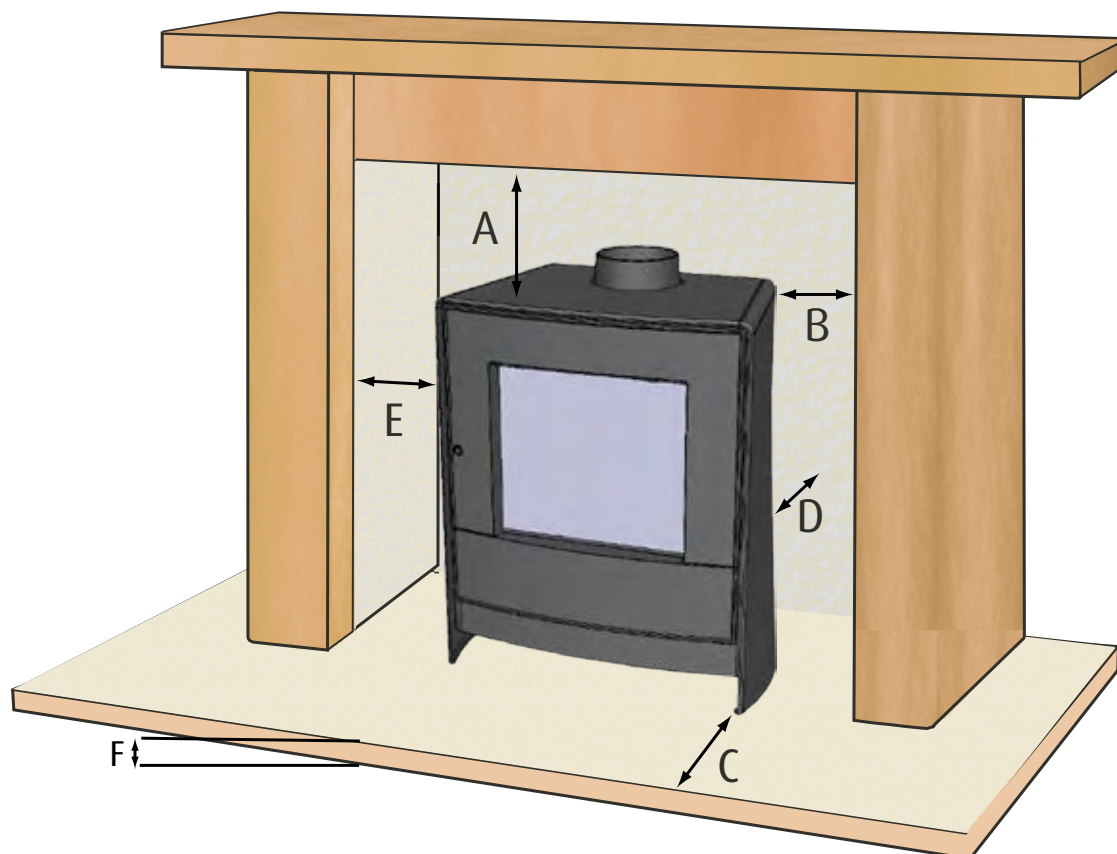

From Non-Combustible Materials					
A	B	C	D*	E	F**
100mm	75mm	300mm	50mm	75mm	12mm

* When being installed with the fresh air kit further clearance may be required so access can be gained for removal of the fresh air kit for cleaning.

** When installed as a free standing appliance or in a prefabricated fireplace. All other applications must conform to current constructional fireplace requirements as per Building Regulations.

General Advice

Not all fireplace apertures are square or rectangular boxes. In cases of where apertures taper or there is an arch top for example a careful assessment should be made to confirm operational clearances can be achieved.

Rules of Thumb

If the clearances at the sides are small but the clearances at the top are large this will still allow access to remove the fresh air kit for cleaning if fitted.

Heat likes to rise, allow as much space as possible above the appliance for heat to escape into the room. If there is only a small aperture above the stove, bring the stove out into the room by at least 2/3rds to assist with the heat distribution.

Always consider that the stove is a heating appliance and would distribute its heat best when free standing. So allow as much space around the stove as possible even if it requires removal of fireplace surround material to create an ideal opening. (Expert building advice may be required).

The Flue

It is possible to remove the top chamber baffle to access the flue for cleaning. However we would advise that if at all possible an external cleaning access is provided. If the chimney has been lined with the same size flue as the flue pipe it will be possible to sweep from the flue access point. If the flue is of a larger size than the flue pipe it may not be possible to use a sweeping brush of an adequate size. In which case another cleaning access will be required. For detailed information see IN1173 The Wood and Mutlifuel Chimney and Installation Guide.

Rear Flue Connection to Flue System

When using the rear flue connection the length of horizontal flue pipe from the rear must not be greater than 150mm (6 Inches). A Tee piece must be used as this provides the flue system with a debris trap and also allows access to the flue.

Minimum Air Setting

The screw is adjusted at the factory to give the maximum air bleed setting. This setting under normal chimney and fuel conditions should be correct.

This facility of having an adjustable minimum air setting provides a positive repeatable air setting that will give the lowest burning rate at which the stove will continue burning when the firing rate control is turned to its minimum position. It will also give a small feed to the air wash when the stove is burning coal, not enough to risk damage to the grate, but enough to help keep the glass clean. It is also an important safety feature. If the stove has been burning with a constant air supply it has been generating and burning the volatile gasses from the fuel. If the air supply is abruptly and completely removed the fire will extinguish but the release of gasses will continue for some time. These gasses will be above their ignition temperature and may potentially ignite all at once if they come into contact with air. The constant air bleed that the small flap allows will keep some of these gasses burning and prevent sudden ignition whilst the generation of gasses reduces.

Adjustment

If it is found that the fire burns for only short periods while set to the "0" position it will be most likely that the flue draught is high. Commonly found in tall or excessive sized chimneys.

To extend the burning cycle the minimum flap can be adjusted to allow less air to enter at low settings. Adjust the flap to give your required settings.

The facia plate on the plexus may have to be removed to access the adjustment screw. Any adjustment should be only undertaken by the commissioning engineer or under direction from the Euroheat Technical Department.

Turn the adjustment screw **clockwise to increase** and **anti-clockwise to decrease** the minimum air setting.

Minimum Air Adjustment Screw



Important:

Do not fully close the minimum air flap.

Remote Control Option

This stove may have the option of remote control.

Fitting the Remote Control Motor

The plexus unit is secured to the base of the stove by 4 wing nuts, they will need to be removed and the plexus unit taken off the stove. The lower cover plate removed from the plexus unit to expose the plexus mechanism. The magnet friction plate, see picture, will need removing to expose the magnet, see picture below.



**Plexus friction plate/
Motor securing plate**



**Plexus friction plate
removed ready to receive
the remote motor**

The motor can now be fitted into the housing and the friction plate refitted as the motor securing plate.

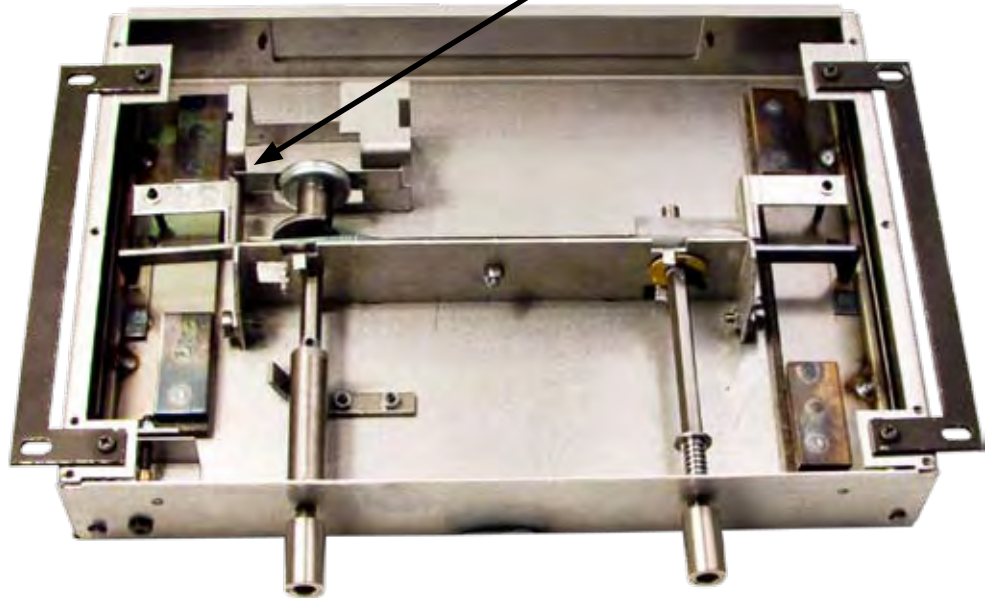

**Plexus friction plate/
Motor securing plate**

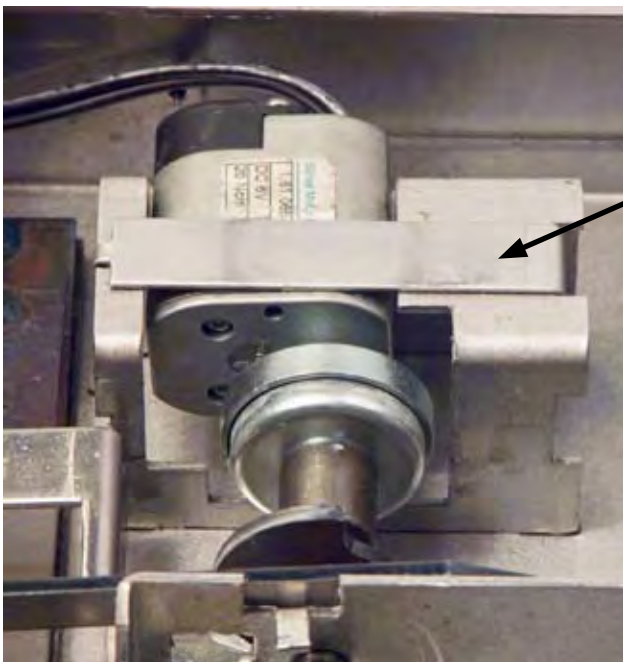

Thread the cable through the hole in the cover plate of the plexus unit and then attach the two wires to the wires at the rear of the receiver box.

The receiver box can then be placed underneath the stove, pushed back, so out of sight.

For full operating instructions for the remote control see the Remote Control Guide.



Contents of the Vent Kit

The venting kit comprises of 2 jubilee clips, 1 meter of 100mm flexible tube and the external cover vent.

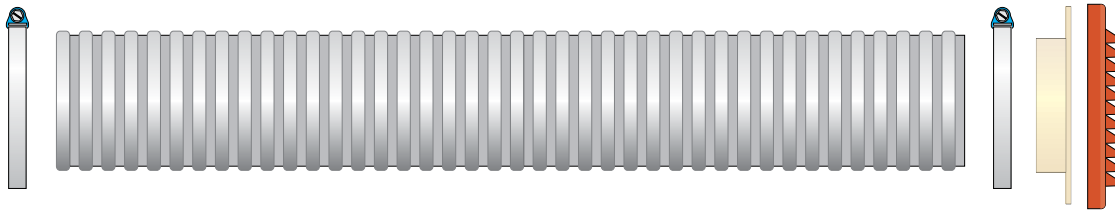

Attach one end of the flexible tube with a jubilee clip to the spigot on the air duct at the rear of the stove. The flexible tube can then be put through the wall and secured to the external vent cover with the other jubilee clip and the vent cover secured to the outside wall.

Vent Kit Adapter for the C23,C33,D33 & NM33



The adapter fits to either the rear or underneath of the plexus.

To fit the vent kit adapter supplied with the stove remove the rear panel from the stove and using the screws, supplied in the bag of installation accessories, attach the adapter to the rear of the plexus unit. On some models there is a plate fitted over the inlet on the plexus for the rear inlet option, so the plexus will need to be removed and the plate removing from the rear and re-fitting over the air inlet on the bottom of the plexus. The vent adapter can then be fitted to the newly exposed rear air inlet and the plexus re-fitted to the base of the stove. The knock out blanking plate on the rear panel should be removed by cutting the tags with a hacksaw blade or twisting with a screwdriver. The NM33 blanking plate is cast and secured by a bracket and 2 screws. Put the vent tube through the back panel and attach to the spigot with the jubilee clip before fitting the back panel to the stove.



The flexible tube can be extended to a maximum of 3 metres. This allows for the venting kit to be used in many applications following more convoluted routes than the one shown below. It can also be attached to a 100mm soil pipe which may have been laid into a floor to duct air to the stove.

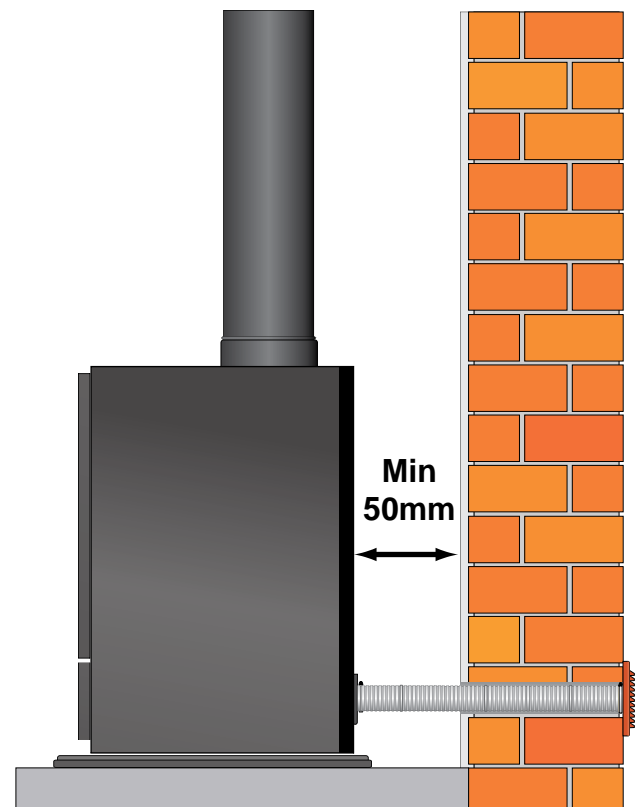

Commissioning Check List

Mark box when completed



Inspect the door and glass seals and ensure all handle latches are adjusted correctly, procedure in the operating instructions.

Check baffle is installed correctly and that the riddling mechanism is operating.

Ensure that the fire responds to the operation of the controls and that there are no visible emissions of the combustion products into the room.

Instruct the user on the use of the tools, operation of the appliance and the summer shut down procedure. Information in the operating instructions.

Instruct the user never to operate the stove with the furnace door open and that the user is aware of the requirement of a suitable fire guard where children, the old or infirm may come into contact with the appliance.

Hand over the installation instructions, operating instructions and completed warranty form to the user. Remind the owner to return the warranty form for registration.

Complete the Stoves Registration Form and Pass to User for Registration

Information from the Euroheat Technical Team

Euroheat and Nestor Martin have a policy of continual research and development and reserve the right to modify its appliances without prior notice.

We make every effort to ensure that the information provided in this document is correct and accurate at the time of printing. Continued updates occur to adapt documents to customer requirements and appliance changes. For the latest editions of all Euroheat documentation visit our web site www.euroheat.co.uk.

We would request that you inform Euroheat of information which you feel is not provided in this document which would assist other users in the future.

The Euroheat Technical Team

Need more info?

with over 10,000 pages of technical information, spare parts, product shots, news and 1001 other things, - you will not find a more comprehensive solution to your queries, whatever time of the day.

www.euroheat.co.uk



Euroheat
Natural Energy Company

Court Farm Business Park, Bishops Frome,
Worcestershire WR6 5AY

Pre sales: 01885 491112
Technical: 01885 491117
Reception: 01885 491100