



Euroheat
Natural Energy Company



Operating Instructions

Harmony Stanford

Conventional Flue & Balanced Flue
Gas Stoves

IN1123 Edition G **June 2009**

PART NUMBER

SERIAL NUMBER

IMPORTANT

READ BEFORE OPERATING THE STOVE

Do not operate the stove with its door open or if its glass is damaged.

Do not operate the stove if the ceramic log effect or coal effect kit is damaged or are not as illustrated in the installation manual. Do not add additional coals or logs to those supplied with the stove.

No attempt should be made to adjust the appearance of the flame by adjusting the burner or ceramic log effect kit without suitable gas analysis equipment. Any change in the appearance of the flame pattern should be reported to your installer.

Improper installation, adjustment, alteration, service, or maintenance can cause injury or property damage.

This appliance must only be installed and maintained by a suitably qualified Gas Safe heating engineer.

Ensure this and all other manuals remain with the appliance

Do not store or use petrol or other flammable vapours and liquids in the vicinity of this or any other heating appliance.

This appliance is designed to become hot and should be located away from pedestrian traffic, furniture and draperies.

Advise all adults and especially children to be alert to the hazard of the stove's high surface temperatures. Supervise young children when they are in the same room as the appliance and fit a suitable fireguard to safeguard young people or the infirm.

It is imperative that all stove and room ventilation air passageways are kept clear.

The appliance should be serviced annually by a suitably qualified Gas Safe registered engineer.

The registration document must be completed by the installer and returned within fourteen days to Euroheat Distributors (H.B.S). Ltd.

First Lighting of the Stove

Read the operating instructions and acquaint yourself with the operation of the controls before attempting to light the stove.

The Stove's Burner Controls

The controls to operate the stove are hidden behind the lower door of the stove, the main door should never be opened while the stove is operating.

To open the lower door lift the left hand side of the door upwards slightly to release the catch and then pull the door outwards.

Depending upon the model of stove the gas valve may be installed vertically or horizontally, however, the operation of the controls is the same for both orientations.



Curing the Stove

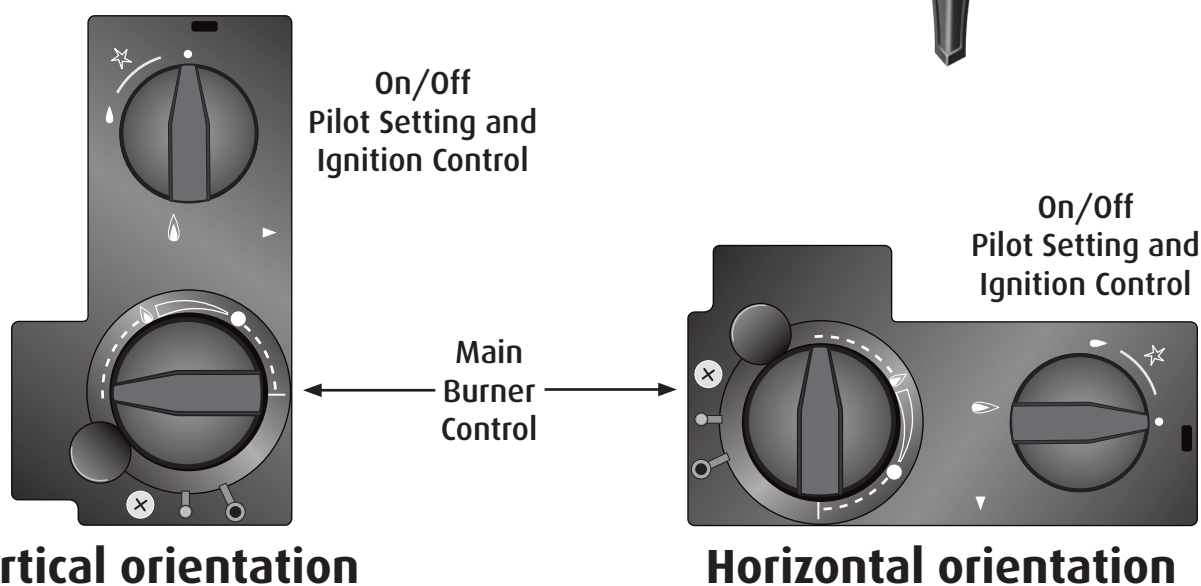

On first lighting the stove will produce a smell and some smoke from the body of the stove, as at the high temperature the paint cures. For the paint to cure fully it requires the stove to be run on its maximum setting for a period of about ten hours, or until the smell of curing stops. This can smell unpleasant and there may be a smoke haze in the room which may activate smoke detectors. We recommend that the room be vacated over this period, doors to the rest of the property are closed and the windows of the room opened to allow the smell to dissipate. Once cured a cast iron stove produces no smell. To ensure the stove operates at its maximum setting if fitted with a thermostatic remote control option ensure that the thermostatic control has been disabled. Please see the remote controls instruction manual (IN1203) for instructions on how to do this, or the stove may not run at its maximum output for the required time to cure the stove.

Mertik Maxitrol Gas Valve

Main Burner Control

The main burner control will set the output from the burner, from maximum to minimum output.

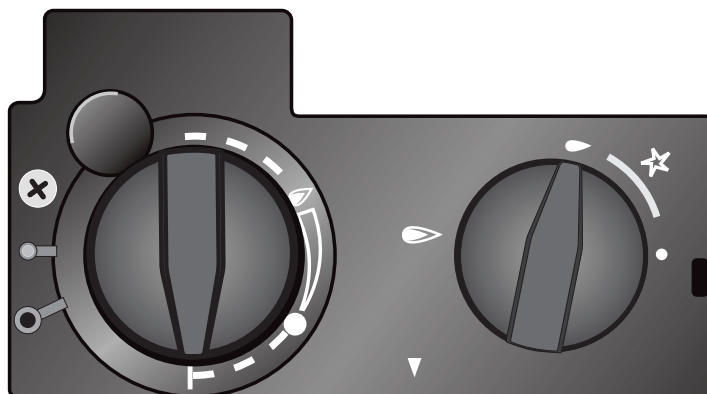

On/Off
Pilot Setting and
Ignition Control

Lighting

Ensure that the main burner control knob is in the off position, see below. Turn the on/off knob, smaller control knob, towards the ignition position then press in and turn anti-clockwise. There will be an audible click as the Piezo spark is generated. If the pilot lights, hold in the control knob for 30 seconds. If it has not lit, repeat the pilot lighting procedure to a maximum of 6 clicks. If after 6 clicks the pilot has not ignited leave the appliance for 5 minutes before attempting again.

Once the pilot has been established, let out the small control knob and turn it fully anti-clockwise.

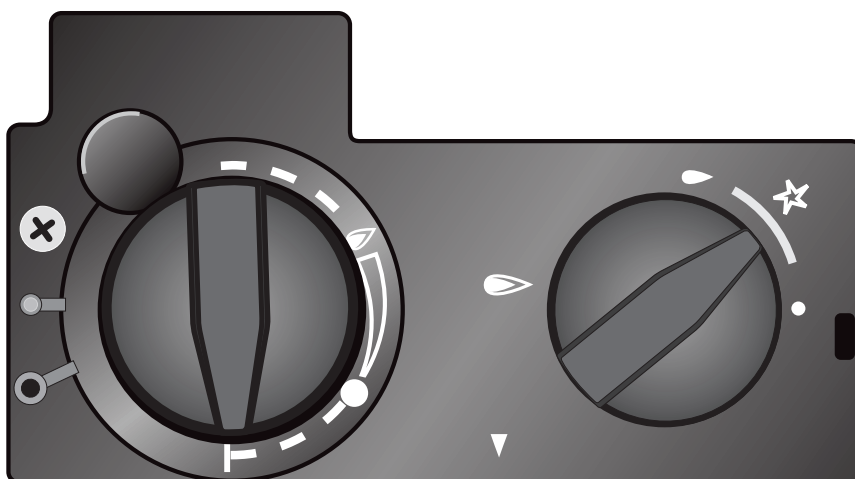

Main Burner Control
The control should be set to its OFF position when the stove's pilot is lit.

**On/Off
Pilot Setting**

Important:

If after 6 attempts to light the pilot flame, including the 5 minutes rest periods between attempts, 30 minutes in total, and the pilot flame will not light contact your Gas Safe service engineer. No further attempts should be made to light the stove.

Main Burner Control

Turn the main burner control anti-clockwise to increase the burner output, clockwise to decrease.

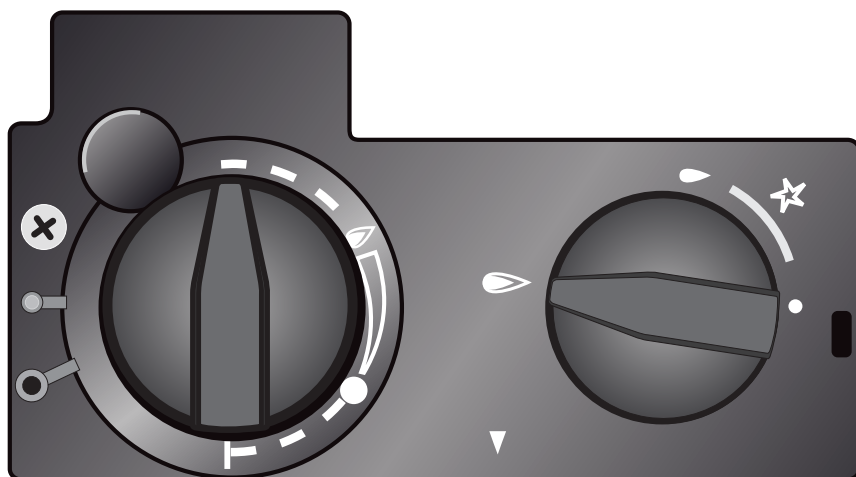

Main Burner Control

Turn the control knob anti-clockwise to increase the burner output, clockwise to decrease. In the picture above it is set in its maximum output position.

On/Off

Turn the control knob fully anti-clockwise to allow gas to the main burner.

Turning off the Stove but leaving it on its Pilot Setting

To turn off the main burner by turning fully clockwise and turn the On/Off control clockwise to the pilot position.

The pilot light can stay alight at all times, allowing for quick and easy use of the stove.

On/Off

Turn the control knob clockwise to the small flame/pilot symbol.

Main Burner Control
Turn the control knob clockwise to its OFF position.

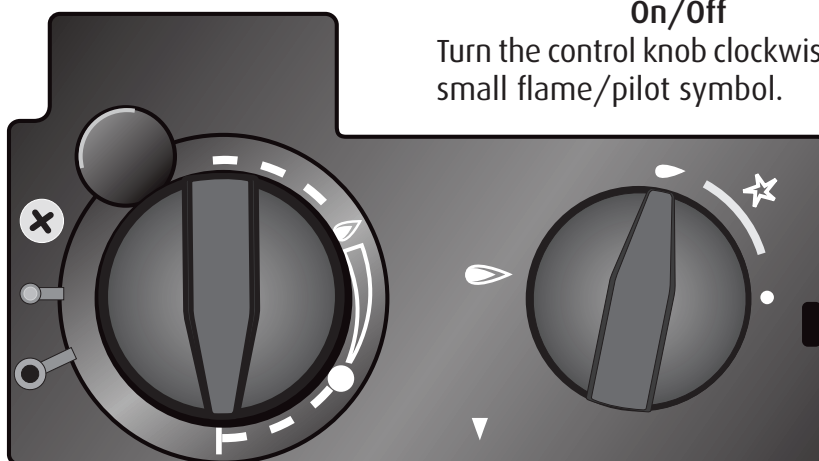

Turning off the Stove and Pilot Light

To turn off the pilot light, push the On/Off control in and turn clockwise to the OFF position.

NOTE:

You will be unable to relight the stove for a period of about 3 minutes after the stove has been extinguished. This is a safety feature and not a fault of the stove.

Cleaning Your Stove

The Glass

For safety reasons never attempt cleaning the glass when the stove is operating or still hot, the stove must be extinguished and allowed to cool. The glass in your stove is specially formulated to withstand the very high temperatures generated within the stove and proprietary glass cleaners are not recommended as their compositions may contain chemicals that will weaken or etch into the glass. Newspaper moistened with water to which a little vinegar has been added will normally remove most staining.

DO NOT operate the stove if the glass is cracked or broken.

A replacement glass and glass seal set can be obtained from your local dealer or by contacting Euroheat Spares Department 01885 491126.

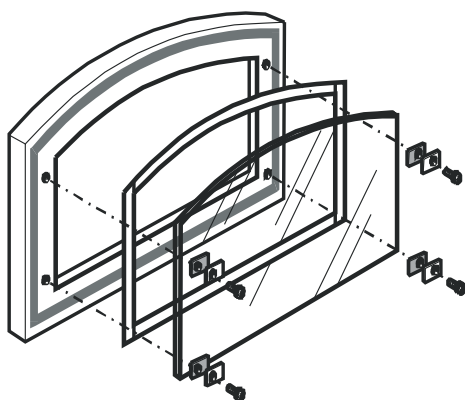

The glass clips should only hold the glass securely and not clamp it tightly. Allowing for its expansion when hot.

The Stove Body

Dusting the stove may be carried out when the stove is at its minimum heat output temperature, using light strokes of a real bristle paint brush. Thorough cleaning, or any attempt to remove marks on the stove body, must only be done when the stove is cold.

Stoves with a matt cast black finish must never be cleaned with a cloth as the texture of the cast iron surface and the paint will abrade and collect lint from the cloth, which will be almost impossible to remove. Vigorous brushing with a stiff bristle brush will remove all dust, but where the paint is marked, the stains are better obliterated with a spray of suitable stove paint rather than attempting to clean them off. Suitable paint may be purchased from your stove retailer, or directly from Euroheat (Part number 40785).

Stoves with an enamel finish should be cleaned with a damp cloth, or very gentle use of a cleaner recommended for enamel finishes. It should be noted that even approved cleaners will damage the highly polished finish of the stove if used too vigorously. All traces of the cleaner must be removed before the stove is lit, and no finishing polishes must ever be used as these will produce an obnoxious smell and leave unsightly streaks on the stove when it becomes hot.

Questions & Answers

Q. Can I run the stove with the door open?

A. No, the stove has been certified as a closed appliance. Operating the stove with the door open may damage the stove, be a fire hazard and cause dangerous gasses to be released into the room.

Q. Can I leave the pilot light on during the heating season?

A. This is permissible and can be very beneficial. It can prolong the life of the thermocouple and the very small amount of heat generated will help maintain a chimney draught.

Q. The pilot flame lights but when I remove the pressure from the on/off control the pilot flame goes out?

A. First ensure that the ON/OFF control has been held in for 30 seconds, if it has, the most likely cause of this is that the thermocouple has failed and will need to be replaced by a suitably qualified Gas Safe engineer.

Q. How often should the stove be serviced?

A. This should be done once a year by a Gas Safe qualified engineer, for not only the efficient running of the stove, but also for the safety of the occupants of the property.

Q. Where can I purchase spare parts for my stove?

A. These can be obtained from the company who supplied you with the stove or directly from the Euroheat web site www.euroheat.co.uk

Q. When heating up, the stove makes a loud noise is this normal?

A. This is called fulmination. Most stoves will make a "ticking" sound when heating up and cooling down. In a few cases this normal ticking will be replaced by a number of loud bangs. This is due to differing rates of expansion of the body of the stove when heating and cooling and has no practical significance for the function of the stove and does not constitute a safety risk or a fault in the construction of the stove.

Q. The stove keeps going out for no apparent reason?

A. Contact your suitably qualified Gas Safe engineer, as it may be that one of the stoves safety devices is shutting the stove off for safety reasons.

Q. I would like to have the remote control option fitted after the stove has been installed, is that possible?

A. Yes, the thermostatic remote control can be fitted at a later date. Contact your local supplier who will be able to supply and install this for you.

Q. What are the benefits of fitting the thermostatic remote control option?

A. The remote control allows for easier manual operation of the stove, as the output can be altered from the comfort of your chair manually using the hand set. Or it can be set to adjust the heat output from the stove to maintain the rooms temperature, using a thermostat within the hand set, so only using the minimum amount of gas to heat the room.

Euroheat and Nestor Martin have a policy of continual research and development and reserve the right to modify its appliances without prior notice. We make every effort to ensure that the information provided in this document is correct and accurate at the time of printing. Continued updates occur to adapt documents to customer requirements and appliance changes. For the latest editions of all Euroheat documentation visit our web site www.euroheat.co.uk.

We would request that you inform Euroheat of information which you feel is not provided in this document which would assist other users in the future.

The Euroheat Technical Team

© Euroheat Distributors (H.B.S) Ltd. June 2009

6

E & OE

Instructions Part Number IN1123 Ed.G

Need more info?

with over 10,000 pages of technical information, spare parts, product shots, news and 1001 other things, - you will not find a more comprehensive solution to your queries, whatever time of the day.

www.euroheat.co.uk



Euroheat
Natural Energy Company

Court Farm Business Park, Bishops Frome,
Worcestershire WR6 5AY

Pre sales: 01885 491112
Technical: 01885 491117
Reception: 01885 491100